

# Installation & Operation Manual

Rev. 11

for the

# CryoTel<sup>®</sup> CT

## Cryocooler & Gen II Controller



The most efficient  
cryocoolers on the market

# The Most Efficient Cryocoolers on the Market

## Sunpower Cryocooler History

CryoTel® cryocoolers are the result of more than 40 years of Sunpower’s technical leadership, innovation, and evolution of the free-piston Stirling engine technology, which we invented in the 1960s. Sunpower started developing compact Stirling cryocoolers in the 1990s. We now sell a variety of affordable CryoTel cryocooler models including the DS 1.5, DS 2.1, MT, CT, & GT.

## Applications

Thanks to the CryoTel cryocooler’s reputation for quality, reliability, exceptional performance, and versatility, they are being used in the following fields and more:

Medical	Low-Noise Amplifiers
Pharmaceutical Processing	Biological Sample Cooling
Aerospace	Semiconductor Manufacturing
Astronomical Telescopes	Imaging Spectroscopy
Telecommunications	Mass Spectrometry
Research & Development	Nuclear Magnetic Radiation
High-Temperature Superconductivity	Refrigeration
Radiation Detection	Environmental Testing
Infrared Detection	Laser Cooling
Security	Ultra-High Vacuum Cold Trap
Gas Liquefaction	Gas Chromatography
SQUID Detection	Satellites
Optics	RF Receivers

## CryoTel Advantages

Our cryocoolers are exceptionally quiet, extremely efficient, highly reliable, environmentally friendly, cost competitive, have a high-power density, and require no maintenance so you can expect many years of high-performance, trouble-free cooling.

## Reliability

CryoTel cryocoolers use our patented gas bearing technology (as opposed to flexure bearings) to produce non-contacting surfaces which eliminates wear. Gas bearing designs are not dependent on precise piston and displacer initial alignment as flexure bearings are. With our gas bearings, the piston and displacer are actively centered throughout the life of the cryocooler. This design is better at accommodating adverse environmental conditions such as shock, vibration, and temperature extremes. In addition to using gas bearings, we also use a hermetically-sealed working environment, and adequate design margin to ensure that our cryocoolers will have a long life.

Our commitment to reliability has paid off, as the current Mean Time To Failure (MTTF) of our legacy CryoTel cryocoolers is over 200,000 hours. NASA has also integrated Sunpower’s free-piston technology in the Advanced Stirling Radioisotope Generator, which requires a 17-year mission life. CryoTel cryocoolers built using our standard manufacturing processes are currently in use on the International Space Station and in the RHESSI satellite which has been orbiting the earth since 2002.

## Efficiency

CryoTel cryocoolers are the most efficient linear cryocoolers on the market. This means that for any given cooling capacity (heat lift), the CryoTel cryocooler has the smallest form factor available, and draws the least amount of power. This is especially beneficial to customers who are integrating a cryocooler into their product.

# Installation & Operation Manual

for the

Rev. 11

## CryoTel<sup>®</sup> CT Cryocooler & Gen II Controller



Sunpower<sup>®</sup> cryocoolers and controllers are designed and manufactured by Sunpower, Inc. in the United States of America under a variety of U.S. and foreign patents. (A detailed patent listing can be found at [www.sunpowerinc.com/patents](http://www.sunpowerinc.com/patents).)

Sunpower, Inc. is a unit of AMETEK<sup>®</sup>, Inc.

Sunpower, the Sunpower graphic identifier, CryoTel, AMETEK, and the AMETEK graphic identifier are trademarks of AMETEK, Inc. and are registered in the U.S. and other countries.

Apiezon<sup>®</sup> is a registered trademark of M&I Materials, Ltd. HyperTerminal<sup>®</sup> is a registered trademark of Hilgraeve, Inc. LabVIEW<sup>™</sup> is a trademark of National Instruments Corporation. Loctite<sup>®</sup> is a registered trademark of the Henkel Corporation. Quad-Lead<sup>™</sup> is a trademark of Lake Shore Cryotronics, Inc. STYCAST<sup>™</sup> is a trademark of the Henkel Corporation. Teflon<sup>®</sup> is a registered trademark of DuPont. Windows<sup>®</sup> is a registered trademark of Microsoft Corporation. ConFlat<sup>®</sup> is a registered trademark of Agilent Technologies, Inc.

Methods and apparatus disclosed and described herein have been developed solely on company funds of Sunpower, Inc. No government or other contractual support or relationship whatsoever has existed which in any way affects or mitigates the proprietary rights of Sunpower, Inc. in these developments. Methods and apparatus disclosed herein may be subject to U.S. Patents existing or applied for. Sunpower, Inc. reserves the right to add, improve, modify, or withdraw functions, design modifications, or products at any time without notice.

© 2016 by AMETEK, Inc. All rights reserved. Printed in the U.S.A.



Sunpower, Inc.  
2005 E. State St., Suite 104  
Athens, OH 45701 USA  
(740)594-2221  
[info@sunpowerinc.com](mailto:info@sunpowerinc.com)  
[www.sunpowerinc.com](http://www.sunpowerinc.com)

## About This Manual

This manual provides installation and operation instructions for a standard CryoTel® model CT cryocooler and Gen II controller in typical installation configurations. Use these instructions as a guide, modifying them where needed to address your particular installation.

This manual is subject to change without notice. All specifications are subject to change without notice. The illustrations in this manual are representative of the CryoTel model CT cryocooler and controller, but may not exactly match your hardware.

If you have any questions about this manual, the cryocooler, or controller, or about any tests or applications you intend to perform, please call Sunpower at (740)-594-2221 or send an e-mail to [info@sunpowerinc.com](mailto:info@sunpowerinc.com).

## Export Notice

This installation and operation manual is provided at no charge.

The export of Sunpower cryocoolers is controlled by the U.S. Department of Commerce's Bureau of Industry and Security. The cryocooler's ECCN number is 6A002.D.2.A. An export license is required for the export of the cryocooler to certain countries. Additional restrictions may apply.



**WARNING:** This product can expose you to chemicals including Lead and Lead Compounds, which is known to the State of California to cause cancer and birth defects or other reproductive harm, through improper use, storage, or disposal of the product. For more information, go to: [www.p65warnings.ca.gov](http://www.p65warnings.ca.gov)



**WARNING:** This product can expose you to chemicals including Cumene, which is known to the State of California to cause cancer, and N-methylpyrrolidone, which is known to the State of California to cause birth defects or other reproductive harm through improper use, storage, or disposal of the product. For more information, go to: [www.p65warnings.ca.gov](http://www.p65warnings.ca.gov)

## Revision History

Rev.	Description of Change	Date
8	<p>This revision updates the manual to cover the latest version of the controller software (version 1.0.8).</p> <p>We also reformatted the entire manual, added front matter pages, updated and added photos and graphics, added a troubleshooting table, added instructions for preparing the RTD wire, added the warranty statement, added a sample final test sheet, added performance graphs, removed the section on the test cap assembly, added exported vibration test results, and replaced HyperTerminal® with a generic terminal emulation program.</p>	June 11, 2015
9	<p>This revision updates the manual to cover the latest version of the controller software (version 2.0.0) including:</p> <ul style="list-style-type: none"> <li>• Changed the controller’s reply to the <b>SET_SSTOP=1</b> command in appendix B.</li> <li>• Added the new “very slow” alternating LED flashing state in table 4-1 and added more details to the table.</li> <li>• Revised the return codes of the <b>MODE</b> command.</li> </ul> <p>Clarified the description of the power control mode, the <b>E</b> command, the <b>SET PWOUT=&lt;Value&gt;</b> command, and the <b>SET TBAND=&lt;Value&gt;</b> command.</p> <p>Added the controller’s software code version number to the front cover and title page.</p> <p>Made other minor changes.</p>	July 29, 2015
10	<p>Replaced the passive balancer photo on page 1-4 with a photo of the new-style passive balancer.</p> <p>Clarified the description of the controller on page 1-5 including adding the statement that the controller is specifically configured to control a CT cryocooler. (It cannot be used to control a GT or an MT cryocooler.)</p> <p>Corrected the text in the NW50 Vacuum Flange section on page 1-11 to say that only the removable NW50 vacuum flange has an O-ring. (The welded version of the flange does not have an O-ring.)</p> <p>Added text to the air fins description section on page 1-15 to state that air flow should ideally also be directed over the back end of the cryocooler.</p> <p>Corrected the controller’s part number from 100871 to 100870 in table 2-2 on page 2-2 and in table 3-1 on page 3-1.</p> <p>Changed “Operating” Frequency to “Output” Frequency in table 2-2, Controller Specifications, on page 2-2.</p> <p>Moved the Terminal Emulation Software item from the “Equipment &amp; Accessories Required but not Supplied by Sunpower” table (table 3-3) to the “Optional Equipment &amp; Accessories Offered by Other Companies” table (table 3-4) on page 3-2.</p> <p>Added “Additional Temperature Sensor” to table 3-4, Optional Equipment &amp; Accessories Offered by Other Companies, on page 3-2. This is for use on the cold tip if you’re using a heater on the cold tip to warm it up after power is disconnected from the controller.</p>	May 11, 2016

*(continues on next page)*

## Revision History (continued)

Rev.	Description of Change	Date
	<p>Deleted the cryocooler serial number breakdown details from figure 3-1 on page 3-3.</p> <p>Clarified the operation of an optional heater to heat the cold tip on pages 3-11, 4-3, 4-5, and 4-6. The heater should be shut off when the cold tip reaches 300 K.</p> <p>Added a user-level maintenance task on page 5-1 to periodically clean dust and debris from optional air fins that are installed in an open atmosphere environment.</p> <p>Added a recommendation in the troubleshooting chart on page 5-1 to attach the other end of the RTD cable shield to the cryocooler body or to the cryostat's structure.</p> <p>Rearranged the commands in Appendix B, Command Reference by grouping them by parameter name.</p> <p>Clarified the operation of the cryocooler with a thermostat in the description of the thermostat commands in appendix B.</p> <p>Added information for operation requirements relating to temperature, altitude, and humidity</p> <p>Added Chapter 6 for Troubleshooting</p> <p>Made other minor changes.</p>	
11	Added California Prop65 warning. Edited thermostat switch description	September 6, 2018

# Safety Summary

## Explanation of Symbols

**=== DC or Direct Current**

Warnings, cautions, and notes are used throughout this manual to highlight important information about using the CryoTel® CT system. Warnings and cautions precede the material to which they apply. Notes may precede or follow material to which they apply. Failure to follow the instructions in these warnings, cautions, and notes may void the warranty. If the cryocooler and/or controller are used in a manner not specified by Sunpower, the protection provided by the equipment may be impaired.

**Warnings** provide critical information to be aware of, or precautions to take to prevent serious bodily injury or death.

**Cautions** provide information to be aware of, or precautions to take to prevent situations that could potentially cause bodily injury, equipment damage, or data loss.

**Important** This special type of note emphasizes information that is vital for you to know to ensure the proper operation of the system or the appropriate use of a CryoTel CT system function or feature.

**Notes** provide additional information or useful tips to help you more easily operate or understand the CryoTel CT system.

The following warnings and cautions appear later in this manual and are repeated here for emphasis. When reading through these warnings and cautions, be aware that some of the equipment and functions mentioned are optional and may not be included in your installation.

**Warning – (pg 3-9)** Do not position the cryocooler, controller, or supporting equipment so that it is difficult to operate the disconnecting device

**Warning (pg 3-9)** – Do not drill holes, or in any other way puncture, or attempt to modify, the pressure vessel.

**Warning (pg 3-10)** – Do not apply clamping pressure to the pressure vessel.

**Warning (pg 3-10)** – Do not puncture or otherwise damage the copper service tube.

**Warning (pg 3-10)** – Do not mount the CT by suspending it from the passive balancer mounting bolt.

**Warning (pg 3-10)** – Do not rigidly attach the passive balancer mounting hole to any mounting surface.

**Warning (pg 3-16)** – Do not subject the electrical feedthroughs pins on the end of the CT's pressure vessel to mechanical stress, for example, axial or radial movements; axial, radial, or any other mechanical loads; blows; etc. because that may break the glass insulators around the pins which could cause helium to leak out of the pressure vessel.

**Caution (pg 3-3)** – Do not pick up the CT by the cold finger; pick it up by the pressure vessel only.

## Safety Summary (continued)

**Caution (pg 3-3)** – Protect the cold finger from any unnecessary contact with anything. The slightest dent or distortion will render the unit inoperable.

**Caution (pg 3-3)** – Do not rest the CT on its cold tip.

**Caution (pg 3-3)** – Do not remove the protective cover from the cold weld on the end of the copper service tube.

**Caution (pg 3-3)** – When the cryocooler is placed horizontally on a level bench top or table, support the cryocooler with support blocks or other methods to prevent it from rolling off the table.

**Caution (pg 3-6 & 5-4)** – The RTD is an Electrostatic-Sensitive Device (ESD). Use ESD precautionary procedures, tools, and equipment such as grounding straps, grounding mats, grounding tools, antistatic garments, etc. when handling or making mechanical or electrical connections to this device in order to avoid performance degradation or loss of functionality.

**Caution (pg 3-6)** – Do not use any kind of sharp blade, either in a machine-unit or by hand, to cut apart or otherwise separate the individual wires. This will cause cuts or nicks in the insulation which will cause tearing and separation of the insulation itself when the wires are separated further.

**Caution (pg 3-6)** – Do not use any manual (by hand) method of sanding or scraping the insulation off as a means to separate the wires. This will cause a rough surface that will cause tearing and separation of the insulation itself when the wires are separated further.

**Caution (pg 3-7)** – Do not heat the wires above 220 °C.

**Caution (pg 3-7)** – Do not attempt to strip the individual leads of the RTD wire until the leads have been fully separated as described in the previous sections.

**Caution (pg 3-10)** – Do not apply a pure axial load of more than 300 N (30.50 kg) at the cold tip.

**Caution (pg 3-10)** – Do not apply a lateral load of more than 30 N (3.05 kg) at the surface of the cold tip when the cryocooler is operating, or more than 100 N (10.20 kg) when it is not operating.

**Caution (pg 3-10)** – Do not apply a torque load of more than 142 in-lb (16 N-m) on the cold tip.

**Caution (pg 3-11 & 4-5)** – If operating below 77 K, we recommend you use a heater to heat the cold tip after operation has stopped to avoid possible spontaneous self-excitation of the cryocooler and possible subsequent damage. Contact Sunpower for more information.

**Caution (pg 3-11 & 4-6)** – If using an optional heater to heat the cold tip after power has been disconnected from the controller, the cold tip temperature must be monitored by an additional sensor. When the cold tip reaches 300 K, the heater power must be removed.

**Caution (pg 3-12)** – Do not install the generation II controller in a location that will be subjected to a vacuum. The controller contains capacitors that are not vacuum rated, so they could burst if subjected to a vacuum.

## Safety Summary (continued)

**Caution (pg 3-12)** – If the controller is installed in an enclosure, cooling must be provided.

**Caution (pg 3-16)** – When reinstalling the passive balancer, ensure that none of the four screws on the balancer facing the pressure vessel are directly over either the power cable connector or the service tube elbow to avoid cryocooler damage due to impact with the screws during large amplitude displacements of the passive balancer.

**Caution (pg 3-17)** – When connecting the controller power cable leads to the controller, verify that the correct polarity is observed. Reversed polarity will result in damage to the controller upon startup.

**Caution (pg 4-3)** – When connecting the cooler power cable leads to the controller, verify that the correct polarity is observed. Reversed polarity will result in damage to the controller upon startup.

**Caution (pg 4-3)** – Do not operate the cryocooler without adequate cooling at the heat rejector. Overheating will cause permanent damage to the cryocooler.

**Caution (pg 4-3)** – When the cryocooler is not in operation, a cold tip temperature up to 360 K (87 °C) is permissible, but do not operate the cryocooler unless the cold tip temperature has dropped below 310 K (37 °C) or you risk damage to the cryocooler. (If you're using a heater on the cold tip, make sure to shut it off when the cold tip reaches 300 K.)

**Caution (pg 4-3)** – Do not control power to the cryocooler by making or breaking the power leads between the controller and the cryocooler because the controller needs to run the cryocooler through a start-up sequence before it begins normal operation.

**Caution (pg 4-5)** – Do not cut off power to the cryocooler by breaking the power leads between the controller and the cryocooler.



# Table of Contents

<b>Chapter 1 Equipment Description.....</b>	<b>1-1</b>
General Description.....	1-1
Major Components .....	1-1
Interaction of Major Components .....	1-2
CryoTel CT Cryocooler .....	1-3
Passive Balancer .....	1-4
CryoTel Generation II Controller .....	1-5
RTD (Resistance Temperature Detector).....	1-6
RTD Cable .....	1-7
Cooler Power Cable .....	1-8
RS-232 Serial Communications Cable .....	1-9
Active Vibration Cancellation (AVC) System (Optional).....	1-10
NW50 Vacuum Flange (Optional).....	1-11
4.5-Inch ConFlat Vacuum Flange (Optional) .....	1-12
Custom Vacuum Flange (Optional).....	1-12
Water Jacket for the Heat Rejector (Optional).....	1-13
Water Jacket for the Pressure Vessel (Optional) .....	1-14
Air Fins (Optional).....	1-15
Mounting Plate for the Gen II Controller (Optional).....	1-16
<b>Chapter 2 Specifications .....</b>	<b>2-1</b>
Introduction .....	2-1
Performance Graphs .....	2-4
Power Curve .....	2-6
<b>Chapter 3 Installation &amp; Setup .....</b>	<b>3-1</b>
Introduction .....	3-1
Equipment & Accessories Supplied by Sunpower .....	3-1
Equipment & Accessories Not Supplied by Sunpower .....	3-2
Unpack & Inspect the CryoTel CT System.....	3-3
CT Product & Serial Number Labels .....	3-3
Generation II Controller Label .....	3-4
Final Test Sheet .....	3-4
Prepare the RTD Wire .....	3-6
Cut the Leads .....	3-6
Separate the Leads .....	3-6
Strip & Tin the Leads.....	3-7
Connect the RTD Wire to the RTD Cable.....	3-7
Install the CT Cryocooler .....	3-9
Install the Generation II Controller .....	3-12
Add Wires to the RS-232 Serial Communications Cable Connector (Optional) .....	3-13
Connect the RS-232 Serial Communications Cable.....	3-15
Connect the RTD Cable to the Controller .....	3-15

## Table of Contents (continued)

Connect the Cooler Power Cable to the Cryocooler.....	3-16
Connection to the Supply.....	3-17
Install & Configure Terminal Emulation Software .....	3-18
Power Up the Controller.....	3-22
Verify Proper Communications Between the PC & the Controller.....	3-22
<b>Chapter 4 Operating Instructions.....</b>	<b>4-1</b>
Introduction.....	4-1
Controls & Indicators .....	4-1
Operating Modes .....	4-2
Temperature Control Mode.....	4-2
Power Control Mode .....	4-2
Startup.....	4-2
Connect the Cooler Power Cable to the Controller.....	4-3
Start up the CryoTel CT System .....	4-3
Operating Tasks .....	4-4
Display Cold-Tip Temperature .....	4-5
Display Target Temperature.....	4-5
Set Target Temperature .....	4-5
Shutdown .....	4-5
Soft-Stop Shutdown Method (Recommended) .....	4-5
Alternate Shutdown Method .....	4-6
<b>Chapter 5 Maintenance and Inspection .....</b>	<b>5-1</b>
Directions for Cleaning.....	5-1
Maintenance and Inspection Precautions.....	5-1
User-Level Maintenance and Inspection .....	5-1
<b>Chapter 6 Troubleshooting.....</b>	<b>6-1</b>
Troubleshooting.....	6-1
Test the RTD.....	6-4
<b>Appendix A Exported Vibration Test Results .....</b>	<b>A-1</b>
Exported Vibration Test Summary .....	A-1
Suspended Orientation Test Setup.....	A-2
Suspended Orientation Test Results .....	A-3
Soft Mount Test Setup .....	A-4
Soft Mount Test Results .....	A-5
Soft Mount RMS Acceleration & Force .....	A-7
Hard Mount Test Setup.....	A-7
Hard Mount Test Results .....	A-8
Hard Mount RMS Acceleration & Force .....	A-10
<b>Appendix B Command Reference .....</b>	<b>B-1</b>
Conventions .....	B-1
User-Lockable Commands .....	B-1
Command Listing .....	B-2
Command Descriptions & Examples.....	B-4

## Table of Contents (continued)

Cold Tip Temperature .....	B-4
Display Cold-Tip Temperature .....	B-4
Control Mode.....	B-4
Set Control Mode.....	B-4
Display Current Control Mode .....	B-5
Change Default Control Mode.....	B-5
Configured Cryocooler Type.....	B-5
Display Configured Cryocooler Type.....	B-5
Controller Code Version.....	B-6
Display Controller Code Version.....	B-6
Controller Serial Number .....	B-6
Display Controller Serial Number .....	B-6
Controller Parameters .....	B-7
Reset Controller Parameters to Factory Defaults.....	B-7
Cooler Power as Measured by Controller .....	B-8
Display Cooler Power as Measured by Controller.....	B-8
Current Commanded Power & Power Limits .....	B-8
Display Current Commanded Power & Power Limits.....	B-8
Error Code .....	B-9
Display Error Code .....	B-9
Integral Constant of Temperature Control Loop .....	B-9
Set Integral Constant of Temperature Control Loop .....	B-9
Display Integral Constant of Temperature Control Loop .....	B-10
Operating State .....	B-10
Display Operating State .....	B-11
Proportional Constant of Temperature Control Loop .....	B-11
Set Proportional Constant of Temperature Control Loop .....	B-11
Display Proportional Constant of Temperature Control Loop.....	B-11
Soft-Stop Control Mode .....	B-12
Set Soft-Stop Control Mode.....	B-12
Display Soft-Stop Control Mode .....	B-12
Soft-Stop State.....	B-13
Set Soft-Stop State .....	B-13
Display Soft-Stop State.....	B-13
Target Power Output .....	B-14
Set Target Power Output.....	B-14
Display Target Power Output .....	B-14
Target Temperature .....	B-15
Set Target Temperature.....	B-15
Display Target Temperature .....	B-15
Temperature Band .....	B-15
Set Temperature Band.....	B-15
Display Temperature Band .....	B-16
Thermostat Mode.....	B-16
Set Thermostat Mode.....	B-16
Display Thermostat Mode.....	B-16
Thermostat State.....	B-17

## Table of Contents (continued)

Display Thermostat State .....	B-17
User-Defined Minimum & Maximum Power Output.....	B-17
Set User-Defined Minimum Power Output.....	B-17
Display User-Defined Minimum Power Output .....	B-18
Set User-Defined Maximum Power Output .....	B-18
Display User-Defined Maximum Power Output.....	B-18
Display User-Defined Minimum & Maximum Power Output.....	B-18
User-Lockable Commands .....	B-19
Lock User-Lockable Commands.....	B-19
Unlock User-Lockable Commands .....	B-19
Set User Password.....	B-19
Display User Lock State.....	B-20
<b>Appendix C Warranty Information.....</b>	<b>C-1</b>
CryoTel Product Limited Warranty .....	C-1
Limitations & Exclusions .....	C-1

# Chapter 1

## Equipment Description

### General Description

The Sunpower CryoTel® CT system includes a CryoTel CT cryocooler, a CryoTel generation II controller, a Resistance Temperature Detector (RTD), various cables, and optional equipment. Figure 1-1 shows everything that comes with the system. The cryocooler shown includes two options that your cryocooler may not have: an NW50 vacuum flange, and the air fins heat rejection option.

Once the cryocooler's cold tip is attached to or inserted into the object or space to be cooled (the thermal load), and all the other components of the CryoTel CT system are in place, including the RTD and at least one of the heat rejection options, then the CryoTel CT system will deliver its cooling power (lift) to the thermal load while maintaining the target cold tip temperature.

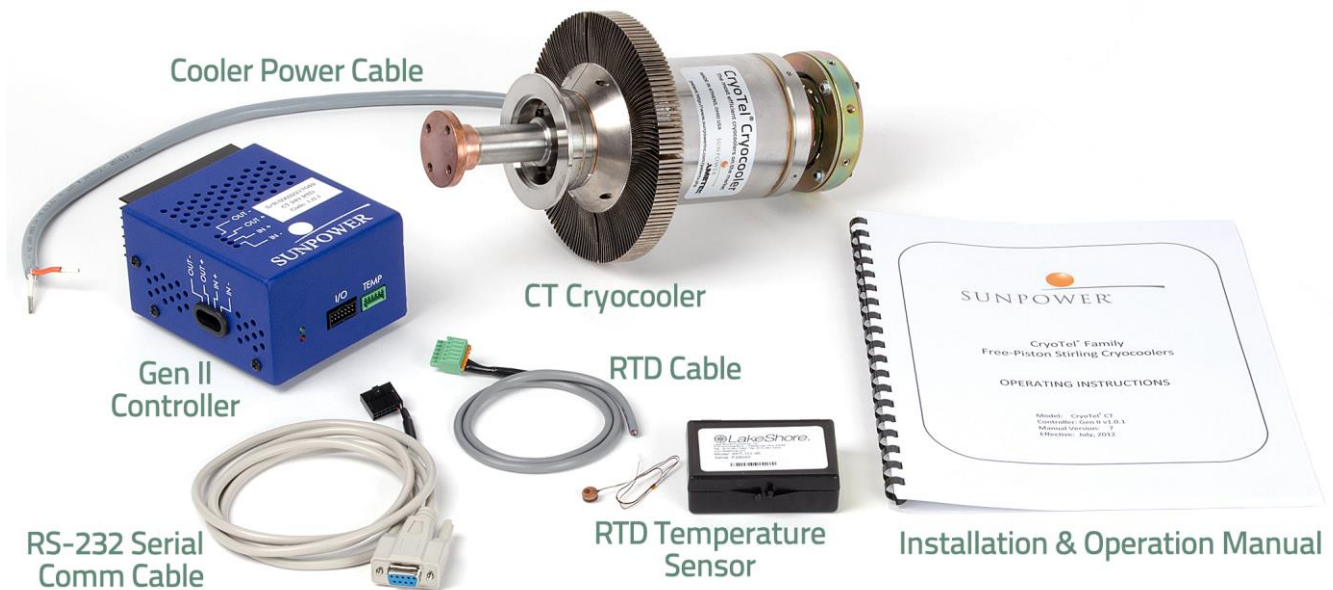

Figure 1-1. Sunpower CryoTel CT System Out-of-the-Box

### Major Components

The rest of this chapter describes the standard equipment shipped with the CryoTel CT system and the related optional equipment that Sunpower offers.

#### Standard Equipment

- CryoTel CT Cryocooler
- Passive Balancer
- CryoTel Generation II Controller
- RTD (Resistance Temperature Detector)
- RTD Cable
- Cooler Power Cable
- RS-232 Serial Communications Cable

**Optional Equipment**

- Active Vibration Cancellation System (AVC)
- NW50 Vacuum Flange
- 4.5-inch ConFlat® Vacuum Flange
- Custom Vacuum Flange
- Water Jacket for the Heat Rejector
- Water Jacket for the Pressure Vessel
- Air Fins
- Mounting Plate for the Generation II Controller

**Interaction of Major Components**

Figure 1-2 shows how the major components of the CryoTel CT system connect with each other and with other equipment outside the system.

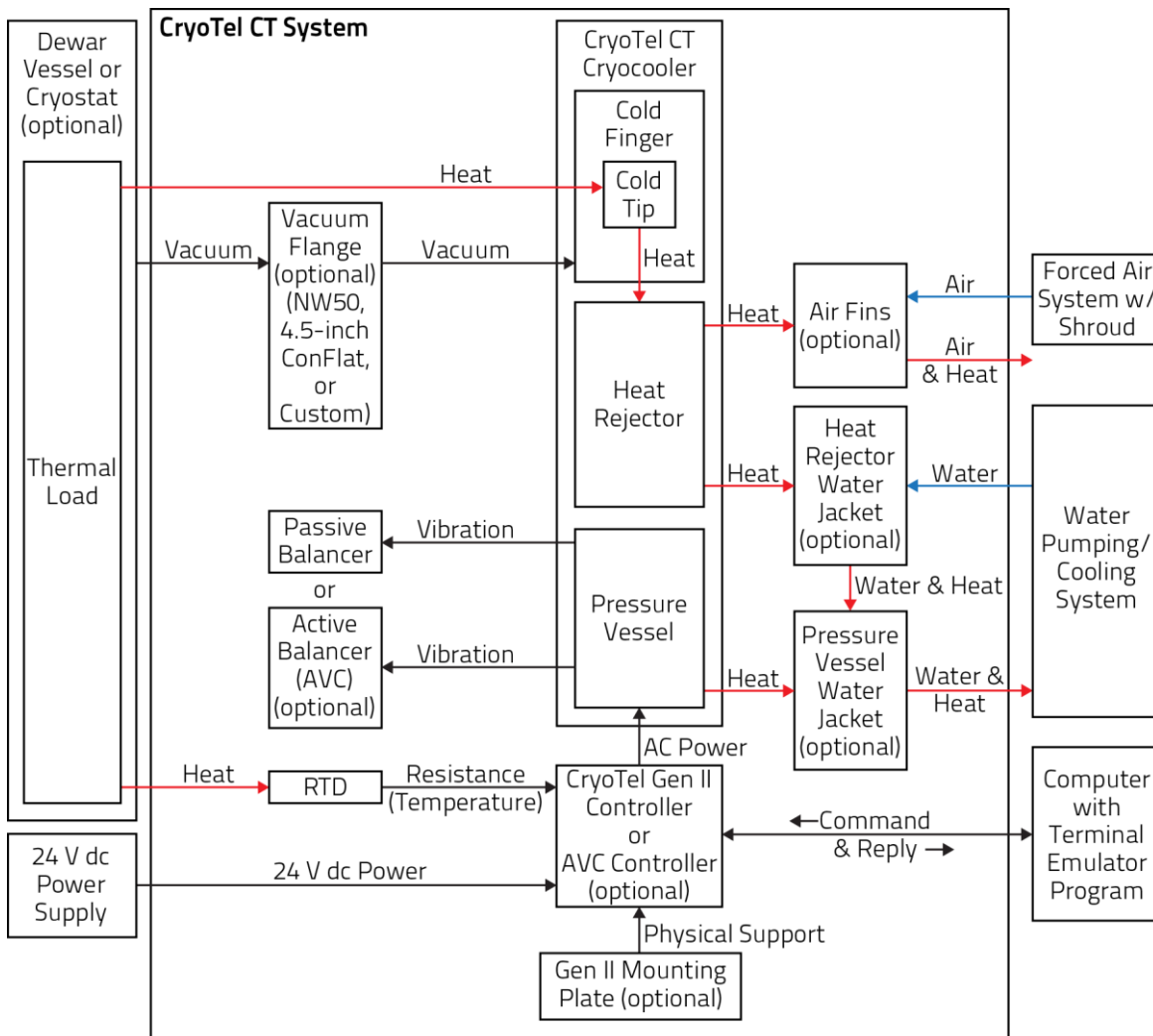

**Figure 1-2. Simplified Functional Block Diagram**

## CryoTel CT Cryocooler

The CT (figure 1-3) is a free-piston, Stirling-cycle-based cryocooler that incorporates a cold finger, an internal piston and displacer, a pressure vessel, and a passive balancer, among other components, into one compact, integral unit. The linear alternator inside the pressure vessel converts electrical power from the controller into linear motion of the piston. The oscillating pressure wave generated by the piston passes from the pressure vessel into the cold finger causing the displacer inside the cold finger to move. The pressure wave and regenerator in the cold finger create a temperature difference which sets up a Stirling thermodynamic cycle which moves heat from the cold tip to the heat rejector resulting in a decreasing cold tip temperature.

The moving parts inside the CT use gas bearings to allow non-contact operation. The gas bearings provide a gas film that acts as a lubricant separating the part surfaces that are in relative motion. The gas bearings work much like an air hockey table where the puck is supported by a layer of air. The gas bearings require the cryocooler to operate at a power level equal to or greater than a minimum threshold level in order for the cryocooler to produce enough pressure to maintain the bearings' non-contact operation. See figure 2-6.

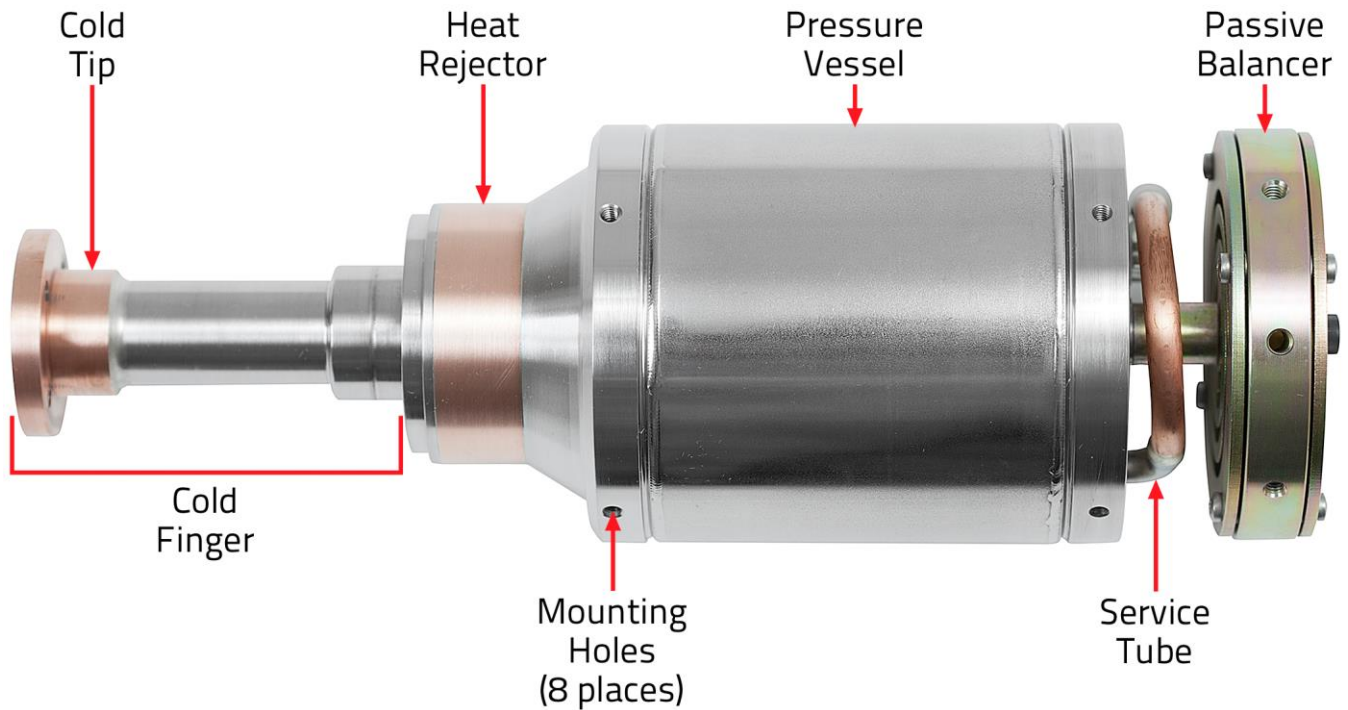

Figure 1-3. CryoTel CT Cryocooler

## Passive Balancer

The passive balancer (figure 1-4) is a removable device that attaches to the pressure vessel end of the cryocooler with one socket head cap screw. The balancer is optimized to absorb 60 Hz vibration energy from the cryocooler. (60 Hz is the frequency at which the cryocooler piston is driven.) The maximum amplitude of the balancer's oscillation is 5 mm.



Figure 1-4. Passive Balancer

## CryoTel Generation II Controller

The CryoTel Generation II Controller (figure 1-5) automatically adjusts the amount of electrical power it sends to the CT based on the temperature input it receives from the RTD and on the default parameters programmed into the controller's software such as target cold tip temperature. (See table B-3.) Note that the controller shipped with the CT cryocooler is specifically configured to control a CT cryocooler; it will not control a GT or MT cryocooler.

If you want to change the controller's parameters or monitor a readout of the cryocooler's performance, then you'll need to connect a computer to the controller's I/O connector via the included RS-232 serial communications cable, and then install terminal emulation software such as PuTTY onto the computer. That software will allow you to send commands to, and receive replies from the controller. Refer to Appendix B for details.

The controller can be positioned in any orientation and still operate, but it cannot operate in a vacuum. It has four rubber feet on the bottom for free-standing operation. The feet can be unscrewed and removed, then the uncovered screw holes can be used to mount the controller to any surface by installing screws from behind the mounting surface, through the mounting surface, and into the screw holes on the bottom of the controller. You can also purchase an optional, flat mounting plate from Sunpower that attaches to the bottom of the controller using the rubber feet screw holes. The plate extends beyond the edges of the controller so that you can mount the controller with screws through the top of the mounting plate.

If the optional active balancer is installed on the cryocooler, then the normal CryoTel Generation II controller is replaced with the AVC controller. (See the AVC System Installation & Operation Manual for details.)



Figure 1-5. CryoTel Generation II Controller

## RTD (Resistance Temperature Detector)

The RTD should be attached to the thermal load or to the CT's cold tip. The resistance across the RTD is proportional to the temperature of the thermal load. The controller reads the resistance of the RTD and converts it to the corresponding temperature for use in its calculations for controlling the CT.

The RTD is supplied already attached to the RTD wire (figure 1-6). The RTD itself is a custom assembly that consists of Lake Shore's PT-111 Platinum Resistance Thermometer attached to a copper mounting bobbin and encapsulated in STYCAST™ epoxy.

The four 12 in (304.8 mm) long polyimide-insulated sensor leads are 36 AWG, phosphor-bronze wires thermally anchored to the bobbin. Teflon® tubing is used as a strain relief to reinforce the leads at the bobbin assembly. If the CT is installed with its cold finger inside a Dewar vessel or cryostat (hereafter referred to as simply a cryostat), then the RTD wires are connected to the feedthroughs inside the cryostat. (The corresponding feedthroughs on the outside of the cryostat should be connected to the RTD cable which connects to the controller. See the next section.) If the CT is not installed on a cryostat, then you have to connect the RTD wire to the RTD-cable as instructed in Chapter 3.

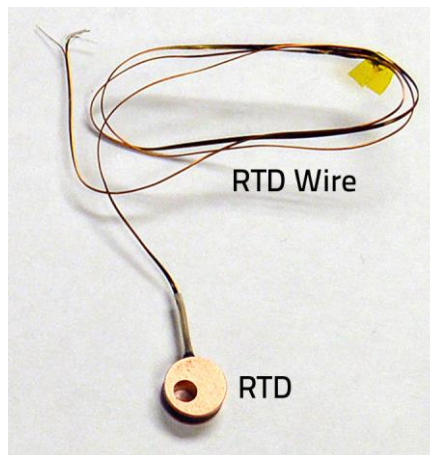

Figure 1-6. RTD With Attached RTD Wire

## RTD Cable

The RTD cable (figure 1-7) is a four-conductor shielded cable with a green, 6-pin connector (Digi-Key P/N 277-1434-ND) attached on one end. The connector is designed to connect to the 6-pin TEMP connector on the controller (pinout in figure 3-9). If the CT is installed with its cold finger inside a cryostat, then the wires from this cable connect to feedthroughs on the outside of the cryostat. (The corresponding feedthroughs on the inside of the cryostat should be connected to the RTD wire.) If the CT is not installed on a cryostat, then you have to connect the wires of this cable directly to the RTD wire as instructed in Chapter 3.

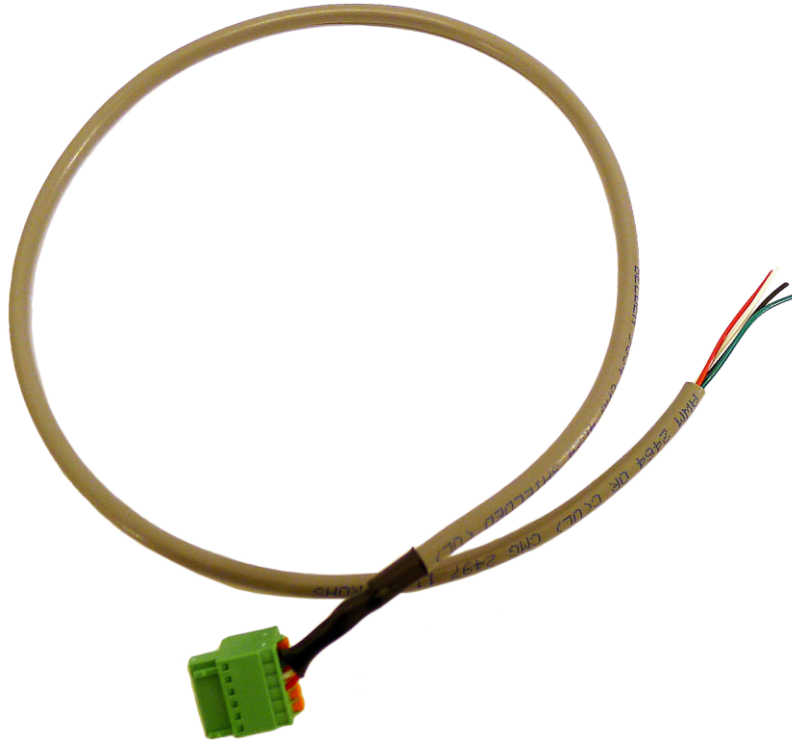

Figure 1-7. RTD Cable

## Cooler Power Cable

The cooler power cable (figure 1-8) supplies electrical power from the controller to the linear alternator inside the pressure vessel of the cryocooler to drive the piston. The cable is a two-conductor cable that has a molded plastic connector on one end that connects to the two feedthrough pins on the end of the cryocooler's pressure vessel. The cable comes with an M3 X 12 socket-head cap screw that is inserted through a hole in the connector and into a screw hole in the cryocooler to hold the connector onto the cryocooler (figure 3-11).

The orange and white 14-gauge conductors on the other end of the cable come with crimp ferrules already attached. The orange conductor is to be inserted into the OUT+ hole in the terminal block on the side of the controller (figure 3-12). The white conductor is to be inserted into the OUT- hole. It is important to ensure that the correct conductor is inserted into the correct hole to prevent damage to the CT.



**Figure 1-8. Cooler Power Cable**

## RS-232 Serial Communications Cable

The RS-232 serial communications cable (figure 1-9) is a 9-conductor shielded cable with a standard, female, 9-pin-D molded connector on one end, and a small, black, 14-pin female connector on the other end.

The molded 9-pin-D connector connects to the RS-232 serial port of the computer that will run the terminal emulation software used to send commands to the controller. (Alternatively, you may connect the cable to a USB port on your computer via an adapter [not supplied] such as the CoolGear Mini USB RS-232 Serial Adapter DB-9 Male. [See table 3-4.]) Only three of the conductors (GND\_ISO [orange], RS-232 TX [output] [gray], and RS-232 RX [input] [yellow]) of this cable are connected into the connector.

The small black connector (Digi-Key P/N WM8039-ND) connects to the 14-pin male I/O connector on the controller (pinout in figure 3-9).



**Figure 1-9. RS-232 Serial Communications Cable**

### Active Vibration Cancellation (AVC) System (Optional)

The optional Active Vibration Cancellation (AVC) system consists of an AVC balancer, and AVC controller, an over-temp thermistor cable, an accelerometer cable, a power wiring harness, and an instrumentation wiring harness as shown in figure 1-10.

The AVC balancer attaches to the back of the cryocooler in place of the passive balancer (figure 1-11) and provides significant active reduction of exported cryocooler vibration by applying an equal force in the opposite direction of the cryocooler’s moving components. The AVC controller replaces the generation II controller and drives the AVC balancer as well as the cryocooler.

Refer to the AVC System’s Installation & Operation Manual (P/N 710MNL-05000-001) for more details.

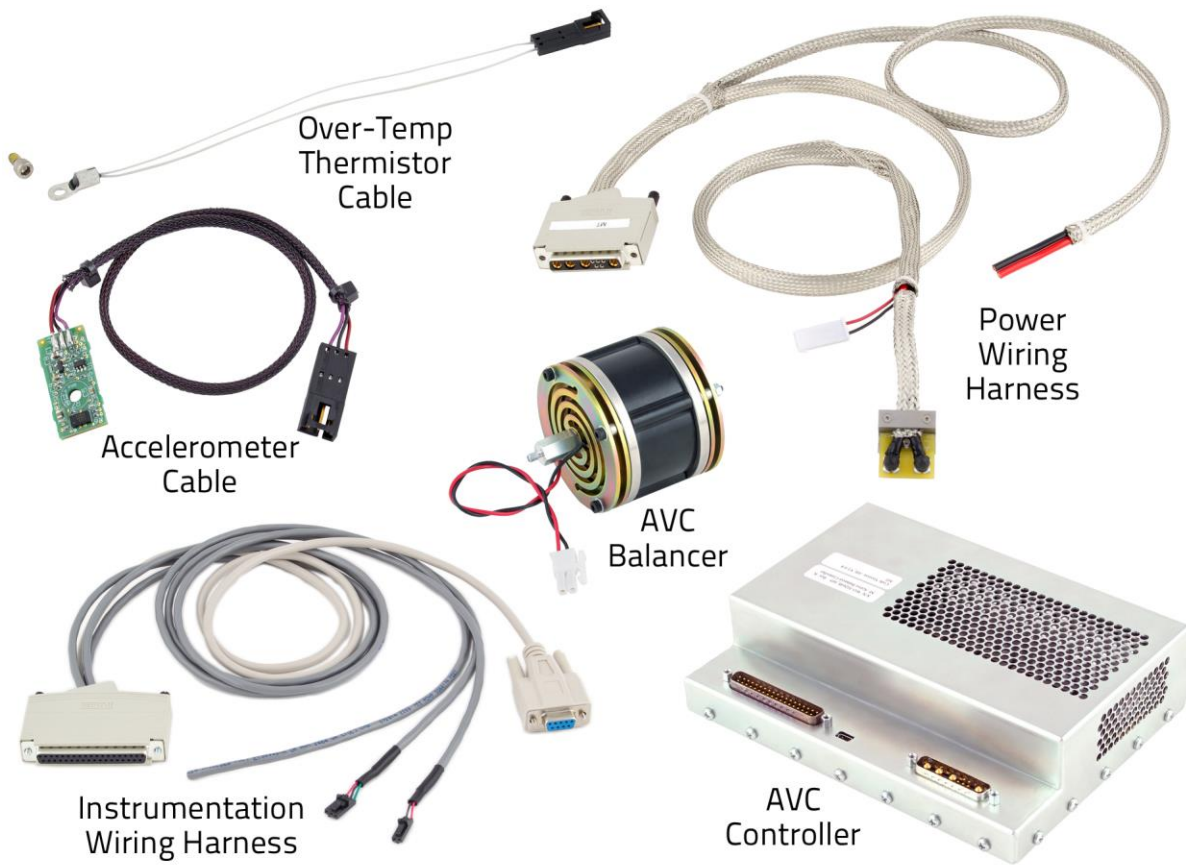

Figure 1-10. AVC System (Optional)



Figure 1-11. AVC Balancer Installed on a CT

### NW50 Vacuum Flange (Optional)

Many applications require the thermal load to be in a vacuum. To accommodate this, Sunpower offers an optional NW50 vacuum flange that is installed at the base of the cold finger so that you can attach the cryocooler via the optional vacuum flange onto a mating vacuum flange on your cryostat so that the cold finger of the cryocooler protrudes into the cryostat.

The optional NW50 vacuum flange can be either removable or welded depending on the customer's needs. The removable NW50 vacuum flange (figures 1-12 & 1-13) attaches to the stainless steel attachment plate at the base of the CT's cold finger (figure 1-14) via four supplied screws. The welded NW50 vacuum flange is welded by Sunpower directly onto the stainless steel attachment plate. The removable NW50 vacuum flange comes with an internal O-ring. The O-ring is subject to wearing out over time if the flange is repeatedly removed and reinstalled. If the O-ring wears out, replace it with a Parker type S1138 2-032 Silicone O-ring with an inner diameter of 1.864 inches and a width of 0.07 inches.



Figure 1-12. Removable NW50 Vacuum Flange (Optional)



Figure 1-13. CT With the Optional, Removable, NW50 Vacuum Flange



Four M3 Mounting Holes for Mounting a Removable Vacuum Flange

Figure 1-14. Mounting Holes for an Optional, Removable Vacuum Flange

### 4.5-Inch ConFlat Vacuum Flange (Optional)

Many applications require the thermal load to be in a vacuum. To accommodate this, Sunpower offers an optional 4.5-inch ConFlat vacuum flange that is welded by Sunpower to the stainless steel attachment plate at the base of the cold finger so that you can attach the cryocooler via the optional vacuum flange onto a mating vacuum flange on your cryostat so that the cold finger of the cryocooler protrudes into the cryostat. One advantage of the ConFlat flange over the NW50 flange is that the ConFlat flange has a metal gasket (seal) that maintains a better vacuum than the O-ring in the NW50.

### Custom Vacuum Flange (Optional)

Sunpower will weld onto the CT any custom flange that has mating surfaces manufactured to the specifications shown in figure 1-15. Custom flanges can be supplied by Sunpower or by the customer. If you are supplying a custom flange, please allow Sunpower to review your design before you fabricate the flange.

NOTES:

- 1 S30400, STAINLESS STEEL 304 ANNEALED
- 2 SIZE ID OF CUSTOM SEAL DESIGN TO FIT OVER  $\phi 42\text{mm}$  MAX CT ACCEPTOR
- 3 DIMENSIONS GIVEN FOR THE CUSTOM FLANGE ARE REQUIRED IN ORDER TO WELD THE FLANGE
- 4 THE FLANGE FEATURES REQUIRED BY THE CUSTOMER MUST BE TO THE RIGHT OF THE 5mm MINIMUM STRAIGHT LENGTH

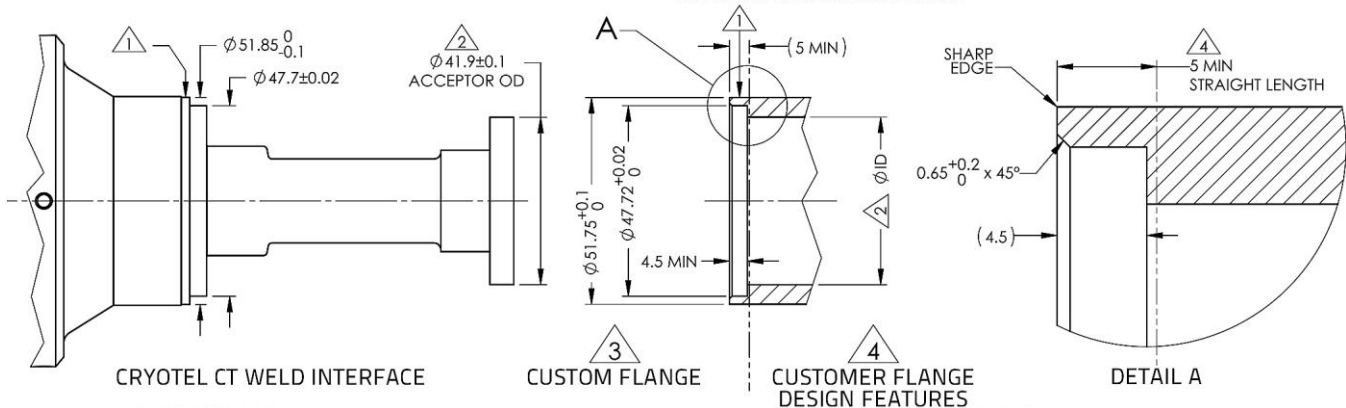

Figure 1-15. Custom Vacuum Flange Specifications

## Water Jacket for the Heat Rejector (Optional)

The optional water jacket for the heat rejector (figure 1-16) provides a pathway for circulating water to pick up and carry away heat from the heat rejector. Two main types of heat rejector water jackets are available: removable (slip fit), or permanent (shrink-fit). The two types look identical. If you're also getting the optional pressure vessel water jacket (next section), then we recommend you get a special permanent version of the heat rejector water jacket with 90-degree-angle fittings (figure 1-17) that match the fittings on the pressure vessel water jacket. The connectors on all the water jackets are ¼-inch Swagelok compression fittings.

The removable water jacket slides onto the heat rejector using a suitable thermal grease to maximize heat conduction. The permanent water jacket is shrink-fitted onto the heat rejector by Sunpower. Water should flow through the water jacket at approximately 0.16 gal/min (10 mL/s) to assure that heat is efficiently carried away from the heat rejector.

The water supply is typically a closed-loop system that pumps the water into the water jacket, cools the water coming out of the water jacket, and recirculates the water back into the water jacket. The temperature of the heat rejector (the reject temperature) is 2–5 °C warmer than the temperature of the water coming out of the water jacket. The temperature of the water should be no higher than 55 °C. The cooler the water, the better the performance, down to a point. The lowest reject temperature a customer can use for a stock CT is about 10 °C. The relationship between reject temperature and performance is reflected in the performance graphs in Chapter 2.



Figure 1-16. Water Jacket for the Heat Rejector (Optional)



Figure 1-17. CT With the Optional 90°-Angle Water Jacket for the Heat Rejector

### Water Jacket for the Pressure Vessel (Optional)

The optional water jacket for the pressure vessel (figure 1-18) slips over the back end of the CT and fits tightly over the pressure vessel (not shrunk fit) with O-rings. Water flowing through the jacket reduces the temperature of the back end of the CT which results in improved cryocooler performance. The jacket is typically connected in series with the optional heat rejector water jacket so that water from a single input line flows through one water jacket and then the other before exiting out a single output line. The connectors on the water jacket are ¼-inch Swagelok compression fittings.



Figure 1-18. Water Jacket for the Pressure Vessel (Optional)

## Air Fins (Optional)

The optional air fins provide a large surface area for heat from the heat rejector to be removed from the air fins by the air that is forced through the air fins. The air fins are made of copper and can be either removable or permanent depending on the customer's needs. The removable air fins option (figures 1-19 & 1-20) comes in two halves that are placed around the heat rejector and then bolted together using two screws. A suitable thermal grease is used between the air fins and the heat rejector to maximize heat conduction. The permanent air fins option is shrunk-fit onto the heat rejector by Sunpower.

In order to use the air fins option, your design must include a shroud around the fins to direct the air flow through the fins and ideally also over the back end of the cryocooler. We also recommend that you install a layer of malleable foam between the shroud and the outer diameter of the fins to seal the gap in order to ensure that the air will go through the fins instead of through the gap. The minimum airflow required to maintain proper cooling is 100 cfm (2.83 m<sup>3</sup>/min), so an appropriately-sized fan should be used.



Figure 1-19. Air Fins (Optional)



Figure 1-20. CT With the Optional Air Fins

### Mounting Plate for the Gen II Controller (Optional)

The optional mounting plate for the controller (figure 1-21) is a thin, flat, aluminum plate slightly larger than the footprint of the controller. It comes with four screws to mount the controller onto the mounting plate. You can then mount the mounting plate with the controller attached to a wall or other surface by inserting screws through the four holes at the corners of the mounting plate and into the wall or other surface.

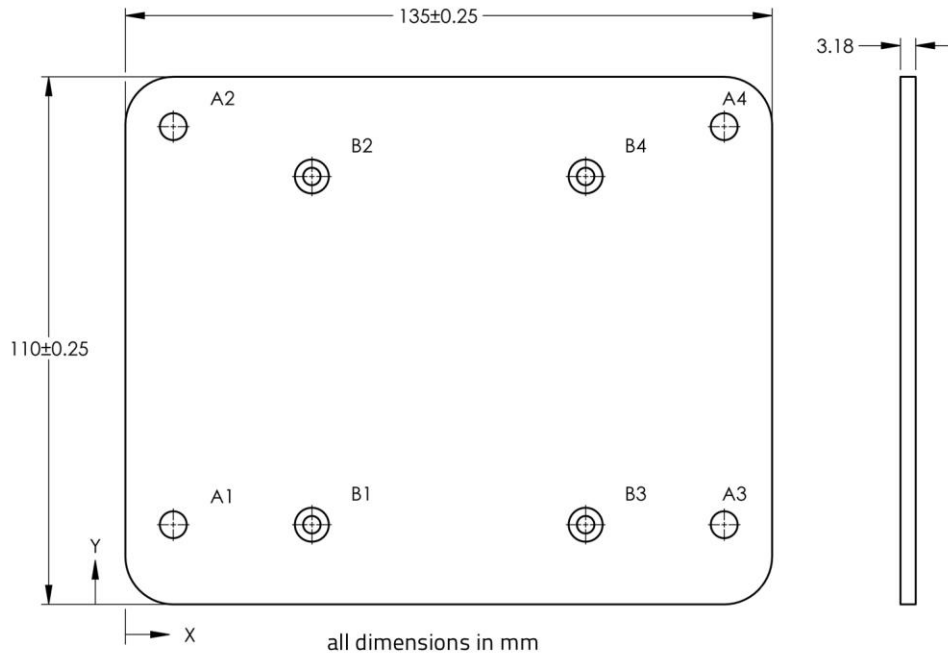

TAG	X LOC	Y LOC	SIZE
A1	10	16.61	Ø 5.61 THRU
A2	10	99.61	
A3	125	16.61	
A4	125	99.61	
B1	38.93	16.61	Ø 3.66 THRU ✓ Ø 7.09 X 100°
B2	38.93	89.22	
B3	96.08	16.61	
B4	96.08	89.22	

**Figure 1-21. Mounting Plate for the Generation II Controller (Optional)**

# Chapter 2

## Specifications

### Introduction

Table 2-1 lists the specifications for the CryoTel® CT cryocooler. Table 2-2 lists the specifications for the CryoTel Generation II controller. Cryocooler performance charts and the cryocooler's power curve follow the tables.

**Table 2-1. CryoTel CT Cryocooler Specifications**

<b>Part Number</b> 100215
<b>Dimensions (figure 2-1)</b> Length 10.3 in (261 mm) (with passive balancer) 8.5 in (217 mm) (without passive balancer) Diameter 1.65 in (41.9 mm) cold tip 2.0 in (52 mm) heat rejector 3.3 in (83 mm) pressure vessel
<b>Weight</b> 6.8 lb (3.1 kg) with passive balancer 5.7 lb (2.6 kg) without passive balancer
<b>Ambient Operating Pressure</b> Can operate the cryocooler in a vacuum
<b>Cold Tip Temperature Stability</b> +0.1 K
<b>Power Input Requirement</b> Variable AC power from the Gen II controller
<b>Nominal Cooler Input Power</b> 160 W
<b>Nominal Lift</b> 11 W (at 77 K cold tip temperature and 23 °C reject temperature)
<b>Operating Orientation</b> Any
<b>Operating Frequency</b> 60 Hz
<b>MTTF</b> 200,000 hr (roughly 23 yr)
<b>Cooling Technology</b> Stirling Cycle

*(continues on next page)*

**Table 2-1. CryoTel CT Cryocooler Specifications (continued)**

<b>Design Life</b>	5 yr
<b>Warranty</b>	2 yr (see appendix C)
<b>Usage</b>	Intended for indoor use
<b>Altitude</b>	Up to 2,000 m (6562 ft)
<b>Operational Ambient temperature range</b>	5°C to 50°C
<b>Maximum Relative Humidity</b>	80% for temperatures up to 31°C decreasing linearly to 50% at 40°C.
<b>Pollution Degree</b>	Pollution Degree 2

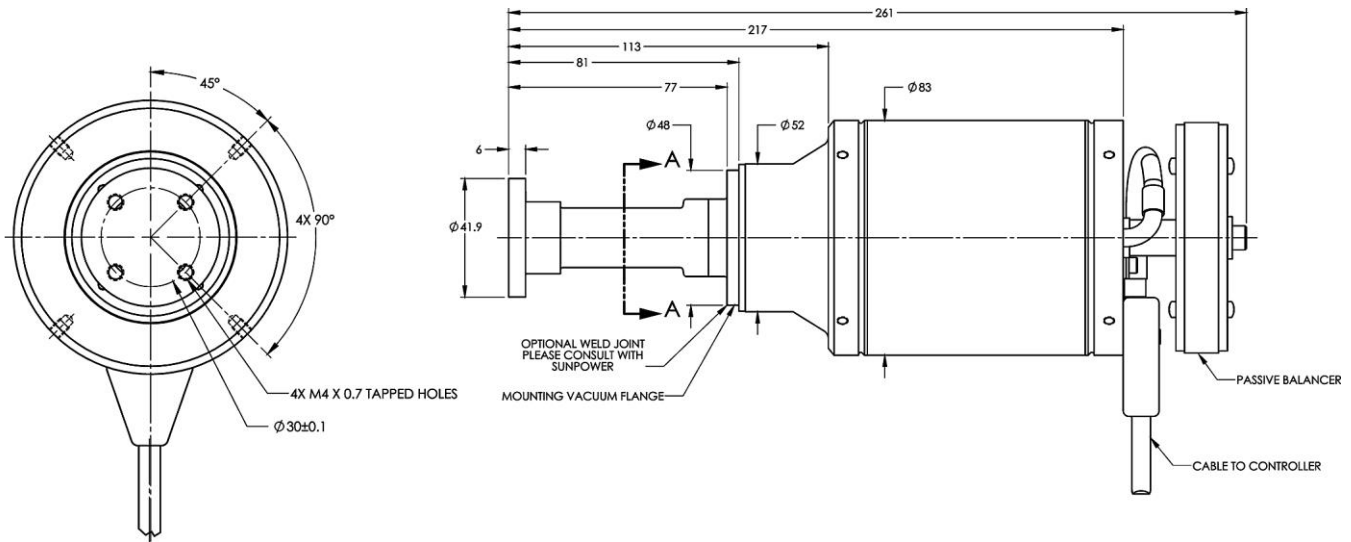

**Figure 2-1. CryoTel CT Cryocooler Dimensions**

**Table 2-2. CryoTel CT Generation II Controller Specifications**

<b>Part Number</b>	100870
<b>Dimensions (figure 2-2)</b>	4.6 in (116 mm) length 3.9 in (98 mm) width 2.6 in (65 mm) height

*(continues on next page)*

**Table 2-2. CryoTel CT Generation II Controller Specifications (continued)**

**Weight**

1.1 lb (490 g)

**Ambient Operating Pressure**

Can not operate in a vacuum

**Voltage Input Requirements**

24 V dc

**Output Frequency**

60 Hz

**Output Power**

**160 W (at 77 K cold tip temperature and 23 °C reject temperature)**

**Temperature Stability**

±0.1 K

**Serial Communications Interface**

RS-232

Baud Rate: 4,800 bps

Data Bits: 8

Stop Bits: 1

Parity: none

Flow Control: none

**Software Interface**

Terminal Emulator

**Control Modes**

Target cold tip temperature or target output power to the cryocooler

**Operating Orientation**

Any

**Warranty**

2 yr (see appendix C)

**Usage**

Intended for indoor use

**Altitude**

Up to 2,000 m (6562 ft)

**Operational Ambient temperature range**

5°C to 50°C

**Maximum Relative Humidity**

80% for temperatures up to 31°C decreasing linearly to 50% at 40°C.

**Pollution Degree**

Pollution Degree 2

**Table 2-3. Cooling and Ventilation Requirements****Requirements for Cooling Water (when using the Sunpower water jacket for the heat rejector)**

Flow Rate: 0.16 gal/min (10 mL/s)

Maximum Inlet Temperature: 55°C

Minimum Inlet Temperature: 10°C

**Requirements for Airflow (when using the Sunpower air fins for the heat rejector)**Airflow Through the Fins: 100 cfm (2.83 m<sup>3</sup>/min)**Ventilation Requirements**

Sufficient ventilation to keep the air around the cooler and controller below 50degC"

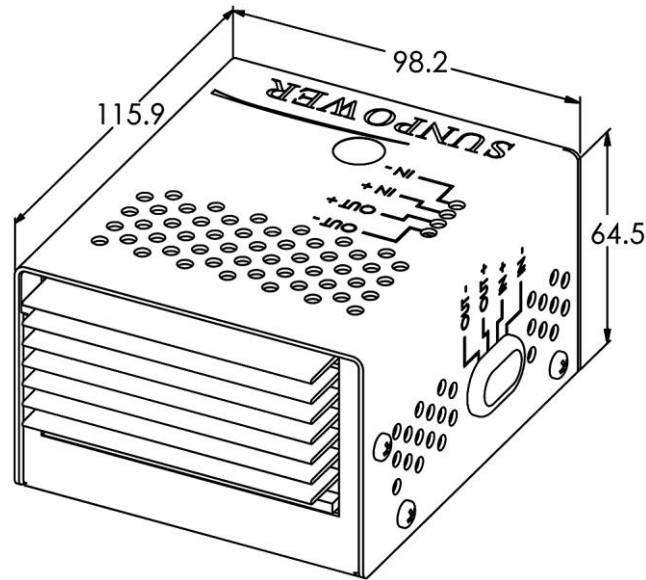
**Figure 2-2. CryoTel Generation II Controller Dimensions**

## Performance Graphs

Figures 2-3, 2-4, & 2-5 show the performance of the cryocooler expressed in various ways. The “lift” referred to in figures 2-3 & 2-4 is defined as the cryocooler’s ability to remove heat from the cold tip while maintaining the stated temperature. For example, the lift for the CT at a cold tip temperature of 77 K and a reject temperature of 23 °C is 11 W. This means you could have an 11 W load and the cryocooler could still maintain the cold tip and load at 77 K.

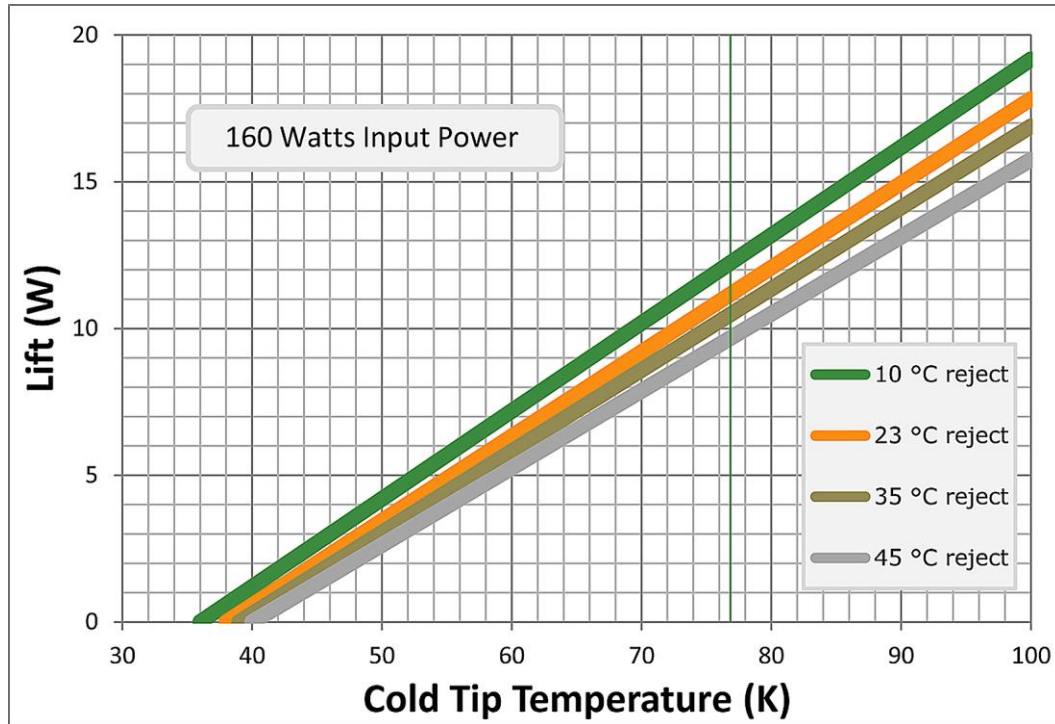

Figure 2-3. CryoTel CT Nominal Performance at 160 W Input Power

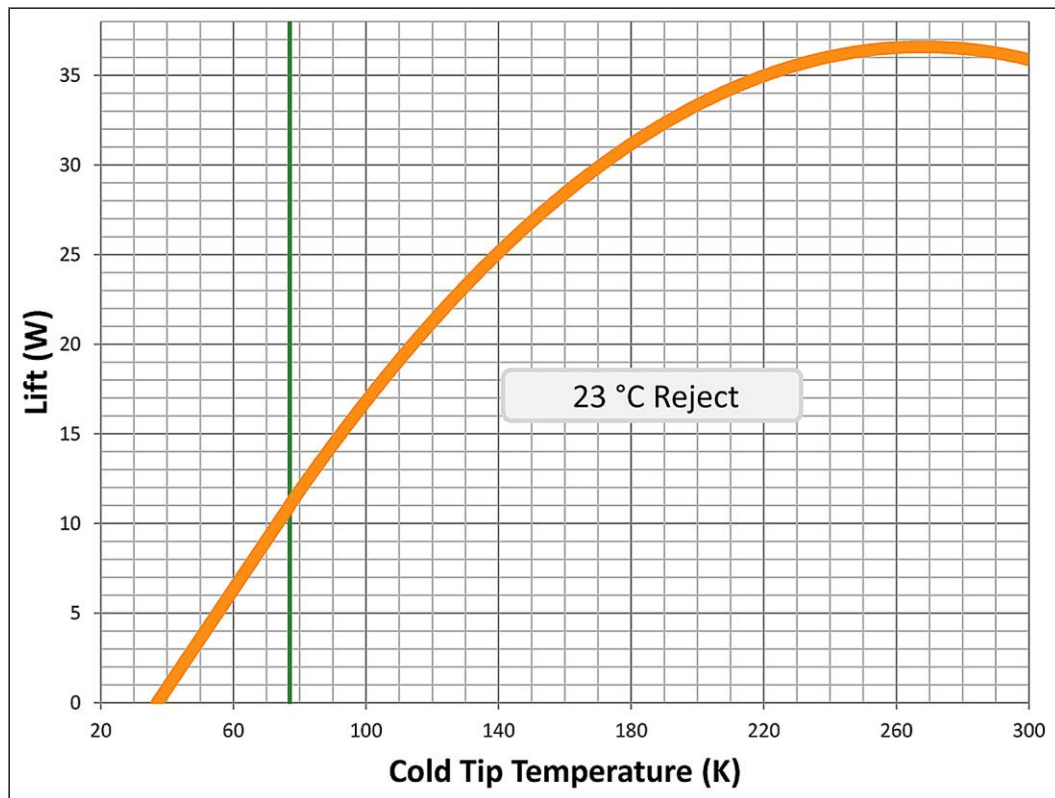

Figure 2-4. CryoTel CT Nominal Performance up to 300 K Cold Tip Temperature

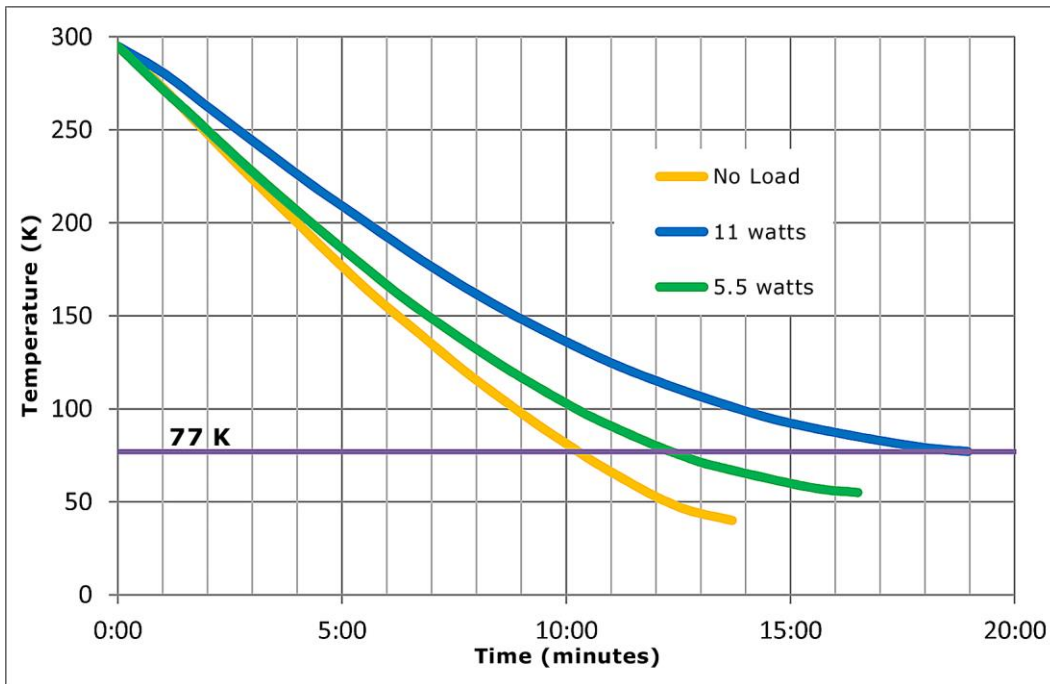

Figure 2-5. CryoTel CT Cooldown Time

## Power Curve

The power curve graph in figure 2-6 specifies the maximum and minimum safe power output to the cryocooler based on the cold tip temperature. The controller will keep the power within the safe range. Refer to the related **E** command (Display Current Commanded Power & Power Limits command) in appendix B.

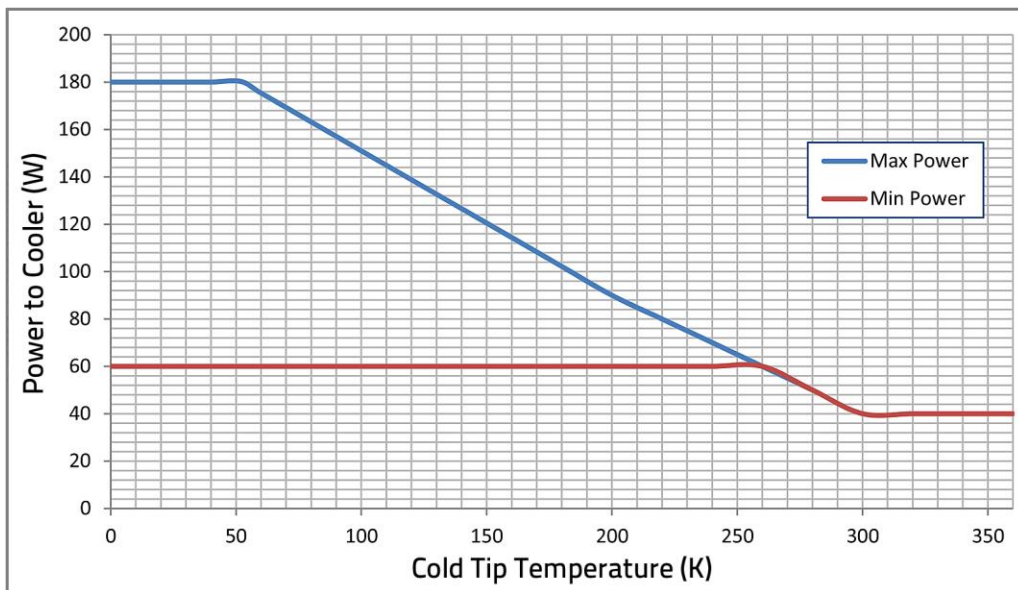

Figure 2-6. CryoTel CT Power Curve

# Chapter 3

## Installation & Setup

### Introduction

Every customer's installation and setup is different, so this chapter can only provide generic installation guidance and some common installation procedures that may or may not apply to your specific installation.

### Equipment & Accessories Supplied by Sunpower

Table 3-1 lists the standard equipment, accessories, and documents normally supplied by Sunpower with the CryoTel® CT system. Table 3-2 lists the optional equipment and accessories offered by Sunpower. Refer to your packing list for the actual list of items supplied with your order.

**Table 3-1. Standard Equipment & Accessories Supplied by Sunpower**

No.	Description	P/N	Qty
1	CryoTel CT Cryocooler	100215	1
2	Passive Balancer for CT	100903	1
3	CryoTel CT Generation II Controller	100870	1
4	RTD with RTD Wire	100300	1
5	RTD Cable	100880	1
6	Cooler Power Cable	100887	1
7	RS-232 Serial Communications Cable	100884	1
8	CryoTel CT Installation and Operation Manual	710MNL-01000-001	1
9	CryoTel CT Quick Reference Guide (in process)	710MNL-01000-002	1

**Table 3-2. Optional Equipment & Accessories Offered by Sunpower**

No.	Description	P/N	Qty
1	Active Vibration Cancellation (AVC) System	N/A	1
	Installation & Operation Manual for the AVC System	710MNL-05000-001	1
2	NW50 Vacuum Flange		1
	<ul style="list-style-type: none"> <li>• Removable (bolted on)</li> <li>• Permanent (welded on)</li> </ul>	100294 100299	
3	Custom Vacuum Flange	N/A	1
4	4.5-Inch ConFlat® Vacuum Flange (permanent–welded on)	100780	1
5	Water Jacket for the Heat Rejector		1
	<ul style="list-style-type: none"> <li>• With Standard Straight Fittings (removable–slip fit)</li> </ul>	100809	
	<ul style="list-style-type: none"> <li>• With Standard Straight Fittings (permanent–shrink fit)</li> <li>• With 90° Angle Fittings (permanent–for use if also using a pressure vessel water jacket)</li> </ul>	100807 100793	

*(continues on next page)*

**Table 3-2. Optional Equipment & Accessories Offered by Sunpower (continued)**

No.	Description	P/N	Qty
6	Water Jacket for the Pressure Vessel	100836	1
7	Air Fins <ul style="list-style-type: none"> <li>• Removable (consists of two halves bolted together around the heat rejector with two screws)</li> <li>• Permanent (shrink fit)</li> </ul>	100615 100132	1
8	Mounting Plate for Generation II Controller	100965	1
9	Final Test Sheet (available upon request) (figure 3-3)	TBD	1

## Equipment & Accessories Not Supplied by Sunpower

Table 3-3 lists the equipment and accessories required but not supplied by Sunpower. Table 3-4 lists optional equipment and accessories offered by other companies for use with the CryoTel CT system.

**Table 3-3. Equipment & Accessories Required but not Supplied by Sunpower**

No.	Description	Qty
1	24 V dc power supply	1
2	Controller power cable (from the power supply to the generation II controller)	1
3	Water cooling/circulating system if using the optional heat rejector water jacket or the pressure vessel water jacket	1
4	Air cooling/circulating system if using the optional air fins	1

**Table 3-4. Optional Equipment & Accessories Offered by Other Companies**

No.	Description	Qty
1	Terminal Emulation Software (such as PuTTY) installed on the connected computer	1
2	USB-to-Serial-Port Adapter (an adapter with a male 9-pin D [DB9] RS-232 serial connector on one end, and a USB type A male connector on the other end, such as the CoolGear Mini USB RS-232 Serial Adapter DB-9 Male, P/N USBG-232MINI from <a href="http://www.coolgear.com/product/mini-usb-rs-232-serial-adapter-db-9-male">http://www.coolgear.com/product/mini-usb-rs-232-serial-adapter-db-9-male</a> ) to allow you to connect the RS-232 serial communications cable to a USB port on your computer	1
3	Cryostat or Dewar Vessel (to enclose the thermal load and the CT's cold finger in a vacuum)	1
4	Heater (to heat the cold tip to supplement the thermal load during operation to meet the minimum load requirement; or for after operation to speed the warmup of the cold tip)	1
5	Additional Temperature Sensor for the Cold Tip (if you're using an optional heater to warm up the cold tip after power has been disconnected from the controller)	
6	Copper Braid (to attach from the cold tip to the heat load)	1
7	Thermostat (to connect across pin 7 [Digital Input 3] and pin 10 or 12 [Onboard Isolated 5 V Output] of the controller's I/O connector to shut down the cryocooler when the temperature is outside of a desired temperature range [see the Set Thermostat Mode section in Appendix B, Command Reference])	1
8	Custom Vacuum Flange	1

## Unpack & Inspect the CryoTel CT System

Although the CT is mechanically robust, it can be damaged if not handled properly. Please observe the following warning and cautions whenever you handle the CT.

**Caution** – Do not pick up the CT by the cold finger; pick it up by the pressure vessel only.

**Caution** – Protect the cold finger from any unnecessary contact with anything. The slightest dent or distortion will render the unit inoperable.

**Caution** – Do not rest the CT on its cold tip.

**Caution** – Do not remove the protective cover from the cold weld on the end of the copper service tube.

**Caution** – When the cryocooler is placed horizontally on a level bench top or table, support the cryocooler with support blocks or other methods to prevent it from rolling off the table.

### To Unpack & Inspect the System:

1. Carefully remove the CT, the controller, the RTD, all supplied cables, and other accessories from their shipping containers and packaging material and place the items on a benchtop or table. Set aside the shipping containers and packaging material in case you need to send anything back to Sunpower.
2. Check to make sure you have all the items you ordered.
3. Inspect all the items for any damage. If anything is damaged, call Sunpower.

## CT Product & Serial Number Labels

Figure 3-1 shows the location of the product and serial number labels on the CT and a closeup of the product label. The cryocooler's part number (100215) is not included on the labels.

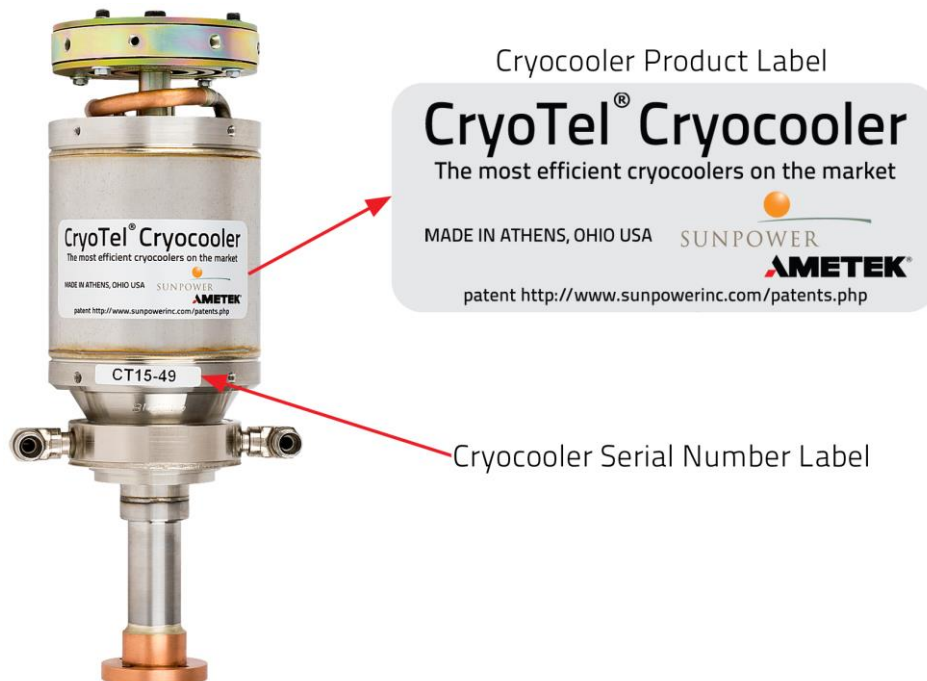

Figure 3-1. Product & Serial Number Labels on the CT

## Generation II Controller Label

Figure 3-2 shows the location of the controller's product label (on the top of the controller) and a closeup of the label. The label lists the serial number of the controller, the type of cryocooler it controls (CT), the controller's input voltage requirement (24 V), the type of cold-tip temperature sensor input it uses (RTD), and the controller's software version number (v2.0.0). The serial number can also be displayed on the connected computer using the **SERIAL** command in the terminal emulation software.

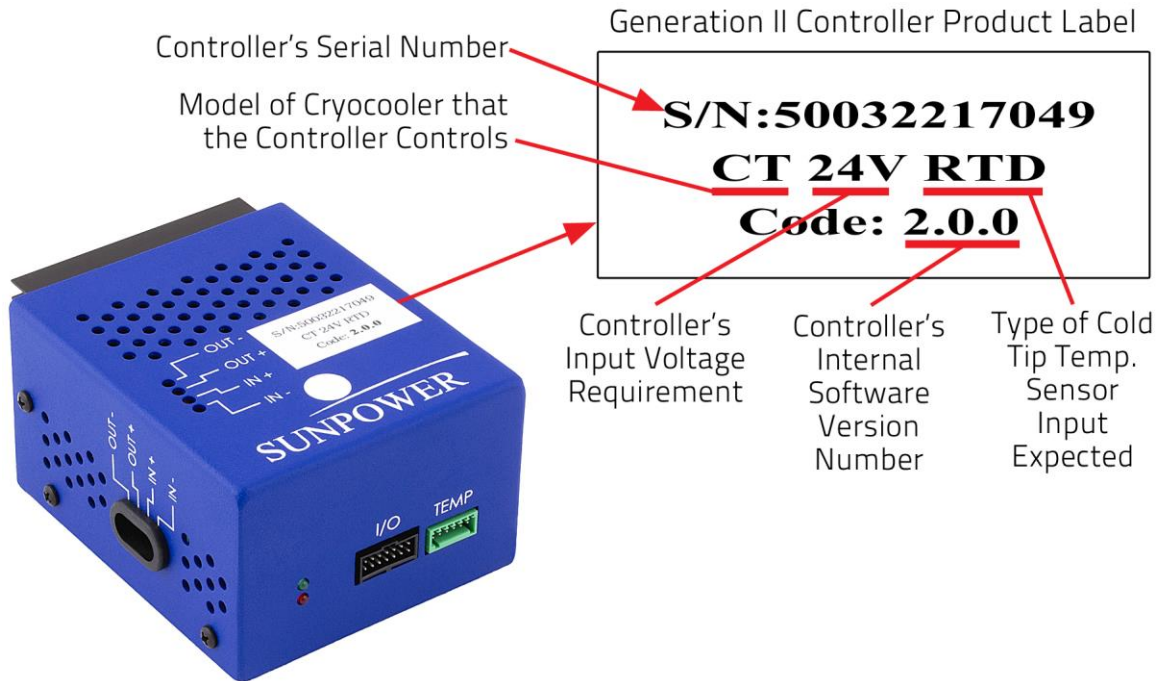

Figure 3-2. Product Label on the Generation II Controller

## Final Test Sheet

The final test sheet, available upon request, includes data from the final test that Sunpower performed on your CT. Figure 3-3 shows a sample final test sheet.

The final test sheet is evidence of Sunpower's internal product qualification. It documents the performance (lift and cold tip temperature) attained by the cooler during final testing at Sunpower prior to shipment. Final testing is in addition to the separate burn-in testing of the cryocooler and the burn-in testing of the controller. The cryocooler is not shipped to the customer unless it meets the minimum performance standards set by Sunpower for each particular model of cryocooler.

It is important to understand that the performance results recorded on the sheet are obtained under very specific testing conditions and that you should not expect to exactly duplicate these results in your particular installation since the conditions will be different.

The top part of the sheet lists the results of testing using a standard CryoTel generation II controller (not the one shipped with the unit) as the input power source. This test is to ensure that the unit works as intended with a CryoTel generation II controller.

The bottom part of the sheet lists the results of testing using a variac (variable auto-transformer) as the input power source.

# CryoTel® Cryocooler Final Test Sheet



Cryocooler Serial Number \_\_\_\_\_ Sample \_\_\_\_\_

Final Test: Gen II Controller	
<b>Test Conditions</b>	
Dewar Vacuum Level (mbar)	1 x 10 <sup>-4</sup>
Ambient Temperature (°C)	23
Reject Temperature (°C)	35
<b>Controller Inputs</b>	
Controller Input Power (W <sub>e</sub> )	180
Controller Input Voltage (V <sub>DC</sub> )	23
Current (A)	10
<b>Cryocooler Performance</b>	
Lift (W)	10
Cold Tip Temperature	77

Final Test: Variable AC Power Input (no controller)	
<b>Test Conditions</b>	
Dewar Vacuum Level (mbar)	1 x 10 <sup>-4</sup>
Ambient Temperature (°C)	23
Reject Temperature (°C)	35
<b>Cryocooler Inputs</b>	
Input Power (W <sub>e</sub> )	160
Frequency (Hz)	60
Voltage (V <sub>AC</sub> )	14
Current (A)	14
<b>Cryocooler Performance</b>	
Lift (W)	10
Cold Tip Temperature (K)	77



2005 E. State Street  
Athens, OH 45701 USA  
www.sunpowerinc.com

The most efficient  
cryocoolers on the market

Figure 3-3. Sample Final Test Sheet

## Prepare the RTD Wire

Figure 3-4 shows the four leads that make up the RTD wire.

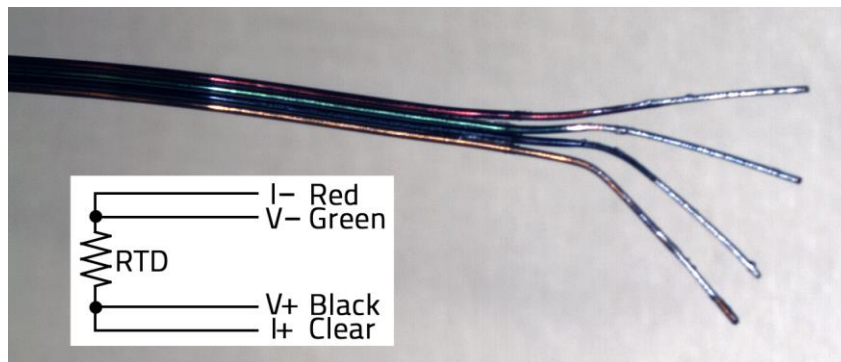

**Figure 3-4. The Four Leads of the RTD Wire**

You can skip this section if the length of the RTD wire is already the correct length for your application. (All wires should be as short as possible to minimize parasitic loading on the cryocooler.) If your application does not use a cryostat, then you'll have to take into account the length of the RTD-cable in addition to the length of the RTD wire since the RTD wire gets attached to the RTD cable in this case.

**Caution** – The RTD is an Electrostatic-Sensitive Device (ESD). Use ESD precautionary procedures, tools, and equipment such as grounding straps, grounding mats, grounding tools, antistatic garments, etc. when handling or making mechanical or electrical connections to this device in order to avoid performance degradation or loss of functionality.

### Cut the Leads

Determine the final length of RTD wire that you'll need, and cut it to length.

### Separate the Leads

Separate the ends of the leads using either mechanical means or heat as described below.

**Caution** – Do not use any kind of sharp blade, either in a machine-unit or by hand, to cut apart or otherwise separate the individual wires. This will cause cuts or nicks in the insulation which will cause tearing and separation of the insulation itself when the wires are separated further.

**Caution** – Do not use any manual (by hand) method of sanding or scraping the insulation off as a means to separate the wires. This will cause a rough surface that will cause tearing and separation of the insulation itself when the wires are separated further.

#### *Separate the Leads Using Mechanical Means*

Individual wires can be separated using a rotary-abrasion style mechanical stripper such as the RT2S Magnet-Wire Stripper from The Eraser Company, Inc. The rotating abrasive heads provide a smooth surface finish critical to separating the wires without nicks or cuts that will cause tearing of the insulation. Automated stripping units that use abrasive rotating heads for “fine wire” or “magnet wire” should also be okay to use, but we recommend that you test any such unit with the intended wire first.

After the individual wires have been separated at the end, you may gently pull the wires to further separate them to the desired length.

### Separate the Leads Using Heat

Quad-Lead™ wires are formed into a “ribbon cable” using Bond Coat 999 bonding film. This bonding agent will soften above 160 °C to 180 °C.

**Caution** – Do not heat the wires above 220 °C.

#### To Separate the Leads Using Heat:

1. Set a hot plate or other heater to between 160 and 200 °C.  
Hot-air guns are not recommended as control and distribution of heat to the wire is much more difficult. At the very least there must be a “hands-free” setup as the wires must be separated while hot.
2. Take the end of the ribbon wire to be separated and place it on the hot surface.
3. Using a pair of fine tweezers, gently push the individual wires apart.  
It may be necessary to bend them or fan them out slightly while on the heater to prevent them from touching and re-bonding once they are removed from the heater.  
Any wire touching the hot surface may separate, so be careful when handling the wire during this process.
4. Remove the wires from the heat.  
Do not try to separate the wires after removing them from the heat.
5. If needed, after the individual wires have been separated at the end, you may gently pull the wires to further separate them to the desired length.

### Strip & Tin the Leads

**Caution** – Do not attempt to strip the individual leads of the RTD wire until the leads have been fully separated as described in the previous sections.

#### To Strip & Tin the Leads:

1. Strip the insulation from the ends of the individual leads of the RTD wire by delicately scraping with a razor blade, fine sand paper, or steel wool.
2. Apply a Rosin Mildly Active (RMA) soldering flux to the leads.
3. Tin all leads with a minimal amount of solder.  
Use a low wattage soldering iron that will not exceed 200 °C.
4. Clean off any residual flux with rosin residue remover.

### Connect the RTD Wire to the RTD Cable

Perform this step only if your application does not involve inserting the CT’s cold finger into a cryostat. This step consists of preparing the leads of the RTD cable and connecting them to the RTD wires. The length of the RTD cable should never exceed 3.0 meters.

#### To Prepare the Leads of the RTD Cable:

1. Strip the insulation from the ends of the leads in the RTD cable.
2. Apply a Rosin Mildly Active (RMA) soldering flux to the leads.
3. Tin all leads with a minimal amount of solder.
4. Clean off any residual flux with rosin residue remover.

### To Connect the RTD Wire to the RTD Cable:

1. Slide a piece of heat shrink tubing onto each lead of the RTD cable down past the stripped part of the leads.
2. Join the leads of the RTD cable with the leads of the RTD wire, matching the colors as detailed in table 3-5.

**Table 3-5. RTD Wire to RTD Cable Connections**

Lead Colors in the RTD Wire	Lead Colors in the RTD Cable	Function
Red	Red	I-/Shield
Green	Green	V-
Black	Black	V+
Clear	White	I+

When a cryostat is not used the RTD cable shield should be attached to the cooler body or conductive structure being used. The other end of the shield should be connected to pin 4 of the green temperature connector.

3. Apply the soldering iron above the joint area until the solder melts, then immediately remove the iron. See figure 3-5.

**Important** – The purpose of figure 3-5 is to show how the heat shrink tubing should be slid onto the wires and how the RTD cable leads are soldered to the RTD wires, but the colors of the RTD cable leads shown in the figure are not accurate; the actual colors are listed in table 3-5.

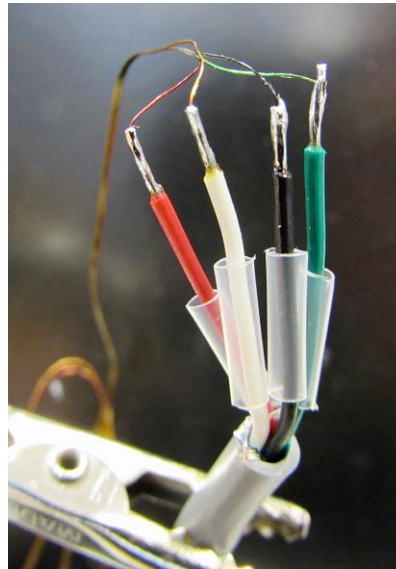

**Figure 3-5. RTD Cable Soldered to the RTD Wire**

- Slide the heat shrink tubing over the solder joints and apply heat to shrink the tubing.  
See figure 3-6.

**Important** – The purpose of figure 3-6 is to show how the heat shrink tubing should be installed over the solder joints, but the colors of the RTD cable leads shown in the figure are not accurate; the actual colors are listed in table 3-5.

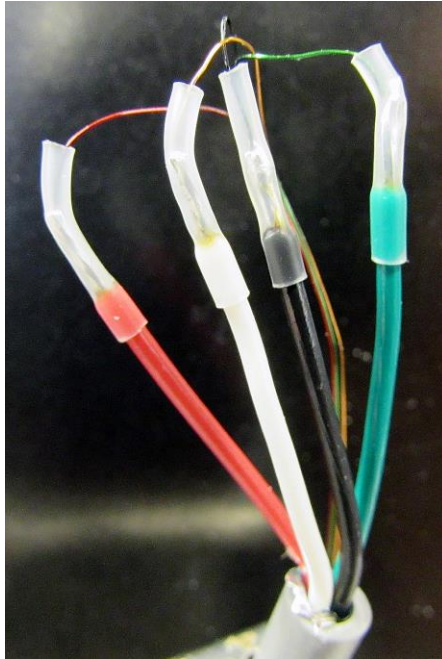

Figure 3-6. Heat Shrink Tubing on the Solder Joints

## Install the CT Cryocooler

The way the CT is installed is highly dependent on the customer's application. These procedures are meant to be a general guide to installing the CT.

You will need to provide for some type of cooling mechanism to cool the CT's heat rejector, such as forced convection (using a fan to blow air through the optional air fins on the heat rejector, or pumping cooling water through the optional heat rejector water jacket), or a custom solid metal conduction method.

The CT can be installed horizontally, vertically, or in any other orientation using the mounting holes on the CT's pressure vessel. Alternatively, the CT can be attached to your cryostat via the optional NW50 or 4.5-inch ConFlat vacuum flange installed at the base of the cold finger so that the cold finger is inserted into the cryostat, and the rest of the CT is cantilevered from the flange. Conversely, the CT can be attached to a mounting surface via the mounting holes in the CT's pressure vessel, and then the cryostat can be cantilevered from the CT's flange.

The CT's cold finger operates best in an insulated vacuum created by a customer-supplied cryostat. The vacuum eliminates possible loading of the cold finger from convection or condensation of elements in the atmosphere such as water vapor and nitrogen.

**Warning** – Do not position the cryocooler, controller, or supporting equipment so that it is difficult to operate the disconnecting device

**Warning** – Do not drill holes, or in any other way puncture, or attempt to modify, the pressure vessel.

**Warning** – Do not apply clamping pressure to the pressure vessel.

**Warning** – Do not puncture or otherwise damage the copper service tube.

**Warning** – Do not mount the CT by suspending it from the passive balancer mounting bolt.

**Warning** – Do not rigidly attach the passive balancer mounting hole to any mounting surface.

**Caution** – Do not apply a pure axial load of more than 300 N (30.50 kg) at the cold tip.

**Caution** – Do not apply a lateral load of more than 30 N (3.05 kg) at the surface of the cold tip when the cryocooler is operating, or more than 100 N (10.20 kg) when it is not operating.

**Caution** – Do not apply a torque load of more than 142 in-lb (16 N-m) on the cold tip.

#### To Install the CT:

1. (Optional) Attach the thermal load directly to the CT's cold tip using one or more of the four M4 threaded holes in the cold tip (figure 3-7).

Use a thin layer of indium, or Apiezon N grease, or similar thermal grease between the thermal load and the cold tip to ensure proper thermal conduction.



**Figure 3-7. Four M4 Threaded Holes in the Cold Tip**

2. (Optional) Attach one end of an optional copper braid onto the thermal load, and the other end of the braid onto the CT's cold tip using one of the four M4 threaded holes in the cold tip (figure 3-7).

Use a thin layer of indium, Apiezon® grease, or similar thermal grease between the braid and the thermal load, and between the braid and the cold tip to ensure proper thermal conduction.

**Important** – The RTD allows the controller to measure and control the cooled object's temperature. The RTD feedback also controls the cryocooler's power ramp-up. If the RTD is not installed properly, the cooling capacity of the cryocooler will be severely limited and temperature control will not function. If the controller detects an improper RTD installed, the controller will issue a temperature sensor error (error code 100000 [six flashes of the LEDs]).

3. Attach the round disk part of the RTD (figure 1-6) onto the thermal load or onto the CT's cold tip using steps a through d below.

**Note** – For optimal temperature control, attach the RTD as close to the cold tip as possible.

The hole in the RTD bobbin will accommodate a #4-40 screw. A brass screw is recommended due to the thermal contractions/expansions of the final assembly.

- a. Clean the threaded hole on the thermal load or on the cold tip with a solvent such as acetone followed by an isopropyl alcohol rinse.  
Allow time for the solvents to evaporate before attaching the RTD.
- b. Apply a small amount of Apiezon N grease to the threads of the screw.
- c. Place an indium washer/preform or a thin layer of Apiezon N grease between the RTD and the mounting surface to ensure good thermal contact.  
An overabundance of grease will increase the thermal barrier, so keep the thickness to 0.05 mm or less.
- d. Insert the screw through the RTD bobbin and tighten the screw firmly enough to hold the RTD in place, but avoid over tightening. A torque of 3–5 in-oz (0.02–0.035 N-m) should be sufficient.

**Caution** – If operating below 77 K, we recommend you use a heater to heat the cold tip after operation has stopped to avoid possible spontaneous self-excitation of the cryocooler and possible subsequent damage. Contact Sunpower for more information.

**Caution** – If using an optional heater to heat the cold tip after power has been disconnected from the controller, the cold tip temperature must be monitored by an additional sensor. When the cold tip reaches 300 K, the heater power must be removed.

4. (Optional) Install an optional heater onto the cold tip to be used during operation to supplement the thermal load to meet the minimum load requirement. It can also be used after operation to decrease warm-up time. If you're using the heater after the power has been disconnected from the controller, then you must install an additional temperature sensor on the cold tip so that you'll know when the cold tip reaches 300 K, at which point the heater should be turned off.
5. (Optional) Insert the CT's cold finger into a cryostat and attach the CT's optional NW50 or 4.5-inch ConFlat vacuum flange onto the cryostat's vacuum flange.
6. If you installed the CT onto a cryostat (step 5), then:
  - a. Attach the RTD wires to the feedthrough pins on the inside of the cryostat.  
For maximum performance, wires should not touch the walls of the cryostat. Contact with the walls will increase the heat loading (conduction) during use and will yield lower available cooling power.
  - b. Attach the RTD cable leads to the pins on the outside of the cryostat. Refer to table 3-5 for connection details.
  - c. The RTD cable shield should be attached to the cryostat body or other conductive structure being used. The other end of the shield should be connected to pin 4 of the green temperature connector. The length of the RTD cable outside the cryostat should never exceed 3.0 meters.
7. (Optional) Attach the CT to a customer-supplied mechanical supporting structure via the M4 threaded mounting holes around the circumference of both ends of the CT's pressure vessel (figure 3-8).

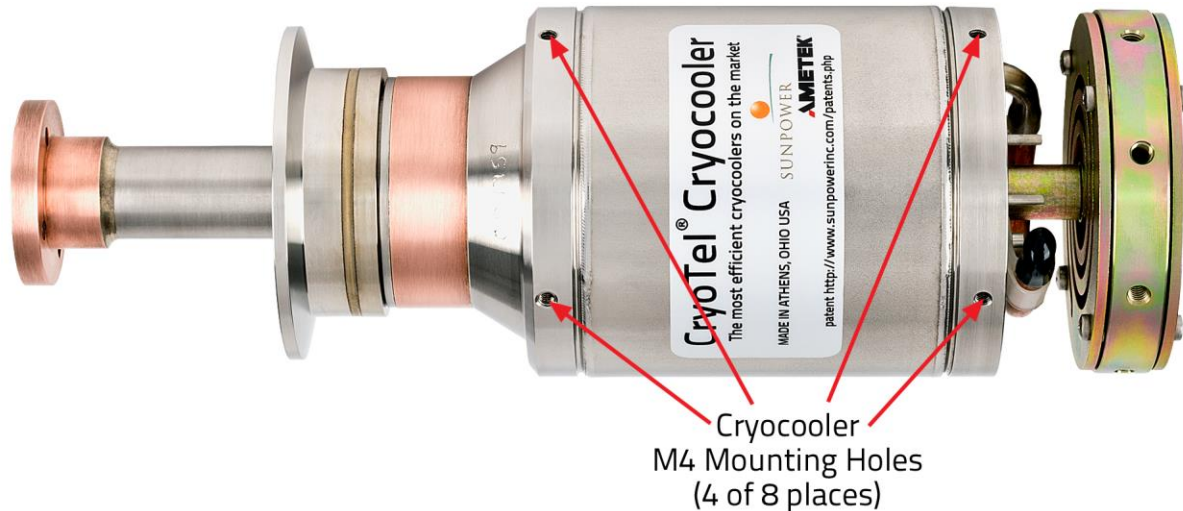

**Figure 3-8. Cryocooler Mounting Holes**

8. (Optional) If using an optional water jacket, do the following:
  - a. Connect the water jacket fittings to your water cooling/circulating system.
  - b. Turn on the water cooling/circulating system and make sure that it operates properly with the water jacket and that there are no leaks.  
Water should be able to flow through the jacket at approximately 0.24 gallons per minute (15 mL per second).
  - c. Turn off the water cooling/circulating system until you have finished installation & setup and are ready to start up the cryocooler. (See chapter 4.)
9. (Optional) If using the optional air fins, do the following:
  - a. Install the fan, shroud, malleable foam, and other equipment associated with your forced-air cooling system.  
Some heat rejection also occurs from the walls of the pressure vessel. Therefore avoid permitting any containment structure for the cryocooler to hinder the heat rejection from any part of the cooler. It is also recommended to electrically interlock the cooling fan and the controller in order to ensure that the cooler cannot operate without also turning on the fan.
  - b. Turn on the fan and any other equipment associated with your forced-air cooling system and make sure that it operates properly with the air fins.  
The minimum airflow required to maintain proper cooling is 100 cfm.
  - c. Turn off the fan and any other equipment associated with your forced-air cooling system until you have finished installation & setup and are ready to start up the cryocooler. (See chapter 4.)
10. (Optional) If using the optional AVC system, install it as detailed in the AVC System's Installation & Operation manual.

## Install the Generation II Controller

**Warning** – Do not position the cryocooler, controller, or supporting equipment so that it is difficult to operate the disconnecting device

**Caution** – Do not install the generation II controller in a location that will be subjected to a vacuum. The controller contains capacitors that are not vacuum rated, so they could burst if subjected to a vacuum.

**Caution** – If the controller is installed in an enclosure, cooling must be provided.

The generation II controller can be positioned in any orientation and still operate. It has four rubber feet on the bottom for free-standing operation. The feet can be unscrewed and removed then the uncovered screw holes can be used to mount the controller to any surface by installing screws from behind the mounting surface, through the mounting surface, and into the screw holes on the bottom of the controller. You can also purchase an optional, flat mounting plate (figure 1-21) from Sunpower that attaches to the bottom of the controller using the rubber feet screw holes. The plate extends beyond the edges of the controller so that you can mount the controller with screws through the top of the mounting plate.

### Add Wires to the RS-232 Serial Communications Cable Connector (Optional)

To access some of the advanced functions of the generation II controller, you have to add extra wires to the RS-232 serial communications cable's 14-pin I/O connector. Some of these functions include the following. See figure 3-9 for a complete pinout of the controller's I/O connector.

- Pin 4 – Digital Out 4 (At Temperature) – This output goes high (5 V) when the cold tip is within the set  $\pm$  temperature band centered on the target temperature (the default band is  $\pm 0.5$  K). When the cold tip temperature is outside of that band, this output will be low (0 V).
- Pin 5 – Digital Input 1 (Soft Stop) – This input only works if the controller's soft-stop control mode is set to Digital Input 1 (mode 1) using the **SET SSTOPM=1** command. Once the controller's soft-stop control mode is set to 1, then setting this input high enables the soft-stop function. The Onboard Isolated 5 V output on pin 10 or 12 on the controller's I/O connector can be used to set this input high. Setting this input low or disconnecting it disables the soft-stop function.
- Pin 7 – Digital Input 3 (Thermostat) – This input only works if the controller's thermostat mode is set to Enabled (mode 1) using the **SET TSTATM=1** command. Once the controller's thermostat mode is set to 1, then setting this input high will allow the cryocooler to run; leaving the pin disconnected will shut down the cryocooler. This operation can be accomplished by connecting a thermostat across this pin and pin 10 or 12, the Onboard Isolated 5 V output pins. When the thermostat is closed (temperature in the desired range), pin 7 is high (connected to the 5 V output pin) and the cryocooler is allowed to run; when the temperature goes outside of the desired range, the thermostat opens, pin 7 goes low (no longer connected to the 5 V output pin), and the cryocooler shuts down.

The I/O connector on the communications cable is a Molex part number 90142-0014 (Digi-Key part number WM8039-ND). To add wires to the connector, you'll need to crimp female contacts onto the wires and then insert them into the connector. The female contacts to use are Molex part number 90119-2109 (Digi-Key part number WM2558-ND). These contacts are for use on 22–24 AWG wire and are made of tin/lead over nickel. Different contacts are available from the manufacturer. The crimper tool to use for 22–28 AWG wire is Molex part number 63819-0200 (Digi-Key part number WM9028-ND.)

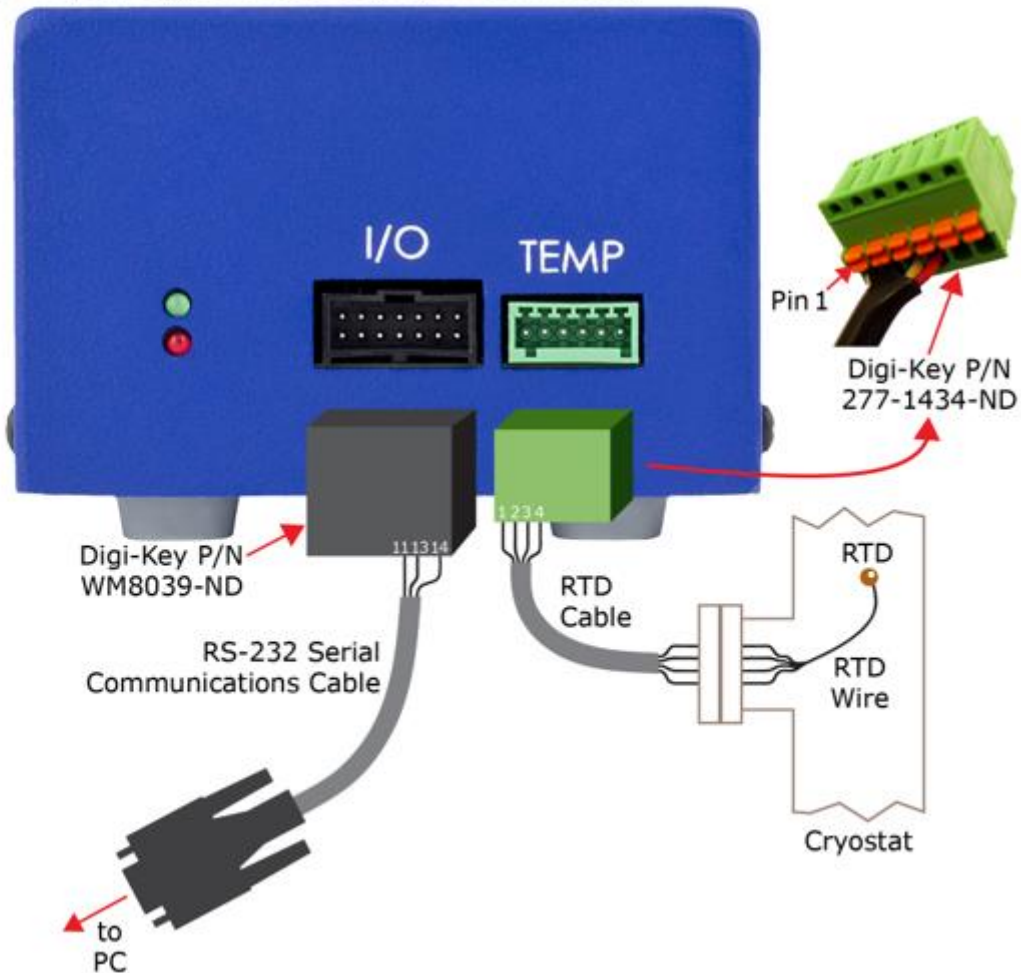
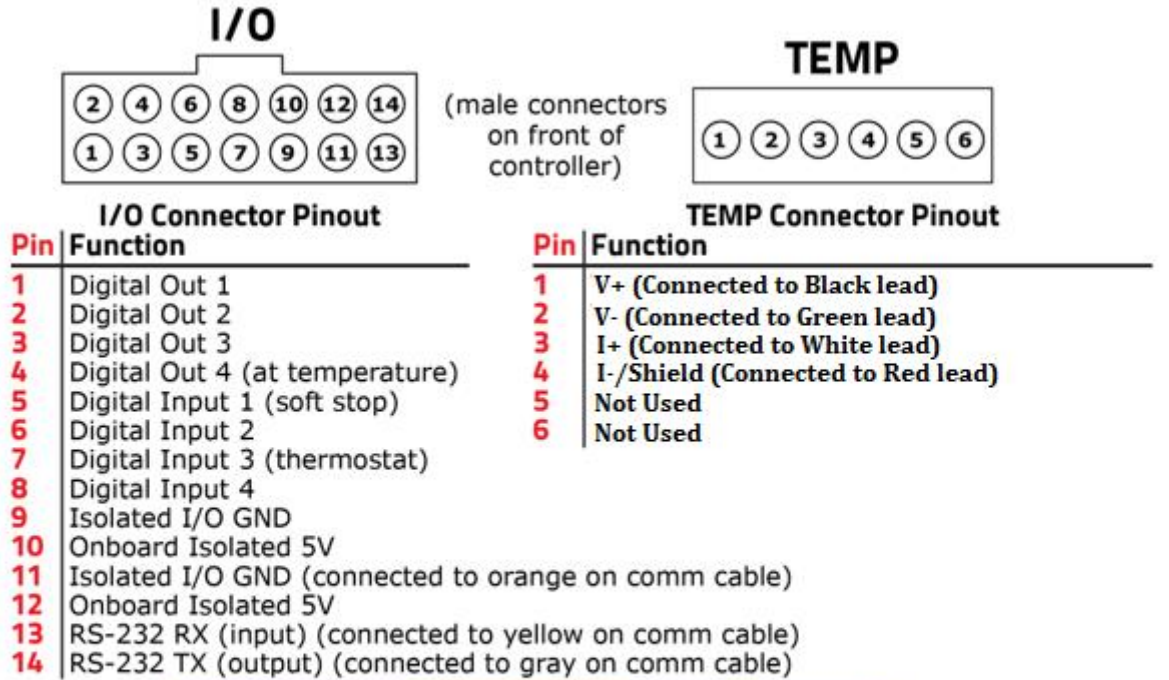

Figure 3-9. Pinout of the Controller's Connectors

## Connect the RS-232 Serial Communications Cable

The RS-232 serial communications cable connects between the controller's I/O connector (figure 3-9) and the computer's RS-232 connector (or USB connector through an optional adapter). See figure 3-10 for details of the wiring between the cable's connectors. The interface uses a baud rate of 4,800 bps, 8 data bits, 1 stop bit, no parity, and no flow control.

### To Connect the RS-232 Serial Communications Cable:

1. Do one of the following:
  - Connect the female 9-pin-D molded connector at the end of the RS-232 serial communications cable to a male RS-232 serial communications port on your computer.
  - Install an optional USB-to-serial-port adapter (item 1 in table 3-4) into a USB port on your computer. The installation will allow you to assign a COM port for the adapter. Once the adapter is installed, connect the female 9-pin-D molded connector at the end of the RS-232 serial communications cable to the adapter.
2. Connect the female 14-pin connector at the other end of the RS-232 serial communications cable to the male 14-pin I/O connector on the front of the generation II controller (figure 3-9).

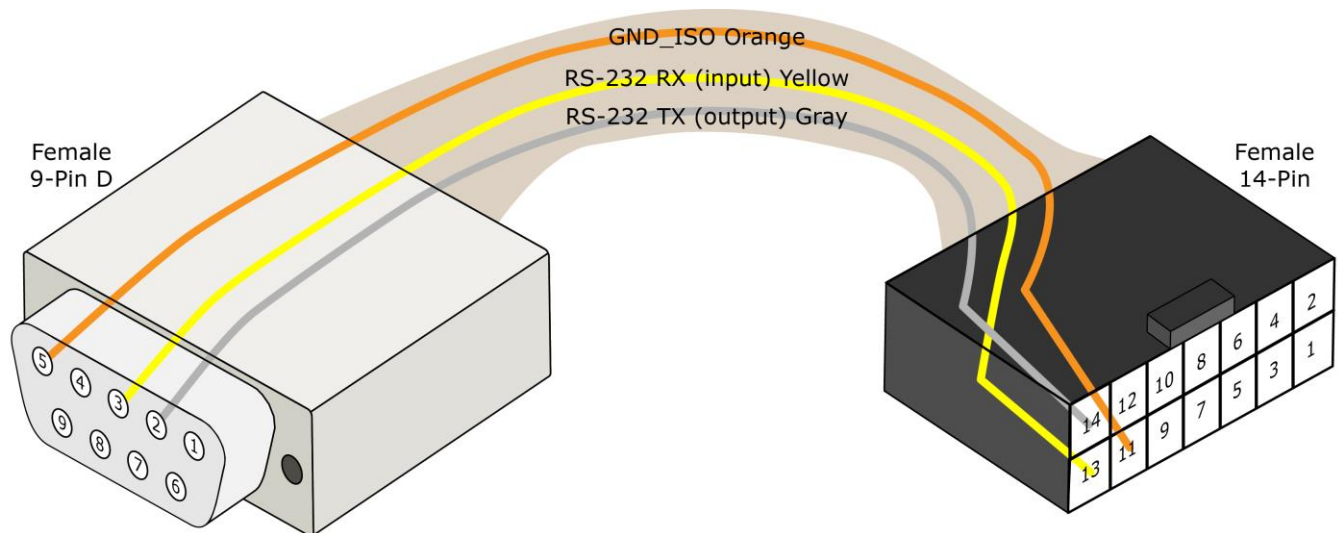

Figure 3-10. RS-232 Serial Communications Cable Wiring Details

## Connect the RTD Cable to the Controller

The RTD cable should already be connected to the RTD wire either directly, or through the feedthrough pins on a cryostat.

### To Connect the RTD Cable to the Controller:

1. Connect the green female 6-pin connector on the end of the RTD cable into the green male 6-pin connector on the front of the controller (figure 3-9).

## Connect the Cooler Power Cable to the Cryocooler

The cryocooler is shipped with the cooler power cable already attached to the cryocooler, but if for some reason the cable has been removed, then use the procedure below to reconnect the cooler power cable to the cryocooler.

### To Connect the Cooler Power Cable to the Cryocooler:

1. If the passive balancer is installed on the pressure vessel, you must remove it to access the electrical feedthrough pins on the end of the pressure vessel. To remove the passive balancer, remove the M5 screw from the center of the passive balancer.

**Warning** – Do not subject the electrical feedthrough pins on the end of the CT’s pressure vessel to mechanical stress, for example, axial or radial movements; axial, radial, or any other mechanical loads; blows; etc. because that may break the glass insulators around the pins which could cause helium to leak out of the pressure vessel.

2. Align the two holes in the molded plastic connector on the one end of the cooler power cable with the two feedthrough pins on the end of the CT’s pressure vessel and press down to connect the connector (figure 3-11).
3. Insert the retaining screw into the connector and use a hex key to tighten the screw.

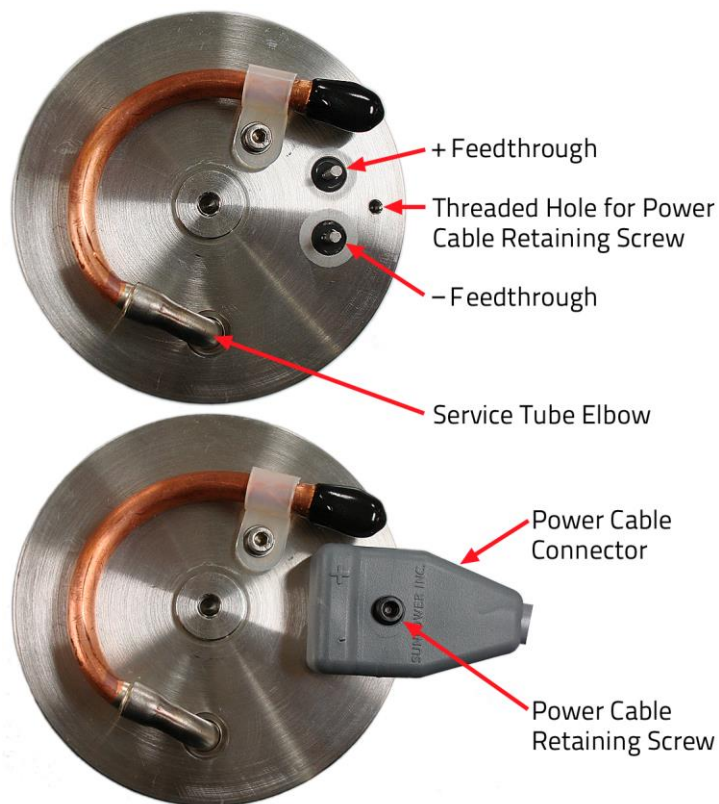

**Figure 3-11. Attaching the Cooler Power Cable to the Pressure Vessel**

**Caution** – When reinstalling the passive balancer, ensure that none of the four screws on the balancer facing the pressure vessel are directly over either the power cable connector or the service tube elbow to avoid cryocooler damage due to impact with the screws during large amplitude displacements of the passive balancer.

4. Place the passive balancer back onto the end of the pressure vessel then reinstall and tighten the M5 screw onto the balancer.

## Connection to the Supply

The customer-supplied controller power cable connects the customer-supplied 24 V dc power supply to the generation II controller. Figure 3-12 shows the function and layout of the terminals on the power connector (terminal block) on the side of the controller. This is where the controller end of the controller power cable is connected.

**Important** – The power-supply end of the controller power cable should not be attached to the power supply until after you install and configure the terminal emulation software later in this chapter.

### To Connect the Controller Power Cable to the Controller:

1. Ensure that the controller power cable is not connected to the 24 V dc power supply.
2. Install crimp ferrules, such as Digi-Key P/N 288-1101-ND onto the two wire leads of the customer-supplied controller power cable using a crimping tool such as Digi-Key P/N 288-1163-ND.

**Caution** – When connecting the controller power cable leads to the controller, verify that the correct polarity is observed. Reversed polarity will result in damage to the controller upon startup.

3. Insert the power return (ground) lead of the controller power cable into the “IN–” terminal inside the power connector (terminal block) opening on the side of the controller.
4. Insert the +24 V lead of the controller power cable into the “IN+” terminal inside the power connector (terminal block) opening on the side of the controller.
5. Insert the end of a small flat-head screwdriver into the screw access slots on the top of the controller and tighten the two terminal block screws onto the two wires of the controller power cable.
6. Ensure that the customer-supplied 24V DC power supply is turned off and disconnected from its source.
7. Connect the power supply end of the customer-supplied controller power cable to the customer-supplied 24V DC power supply.

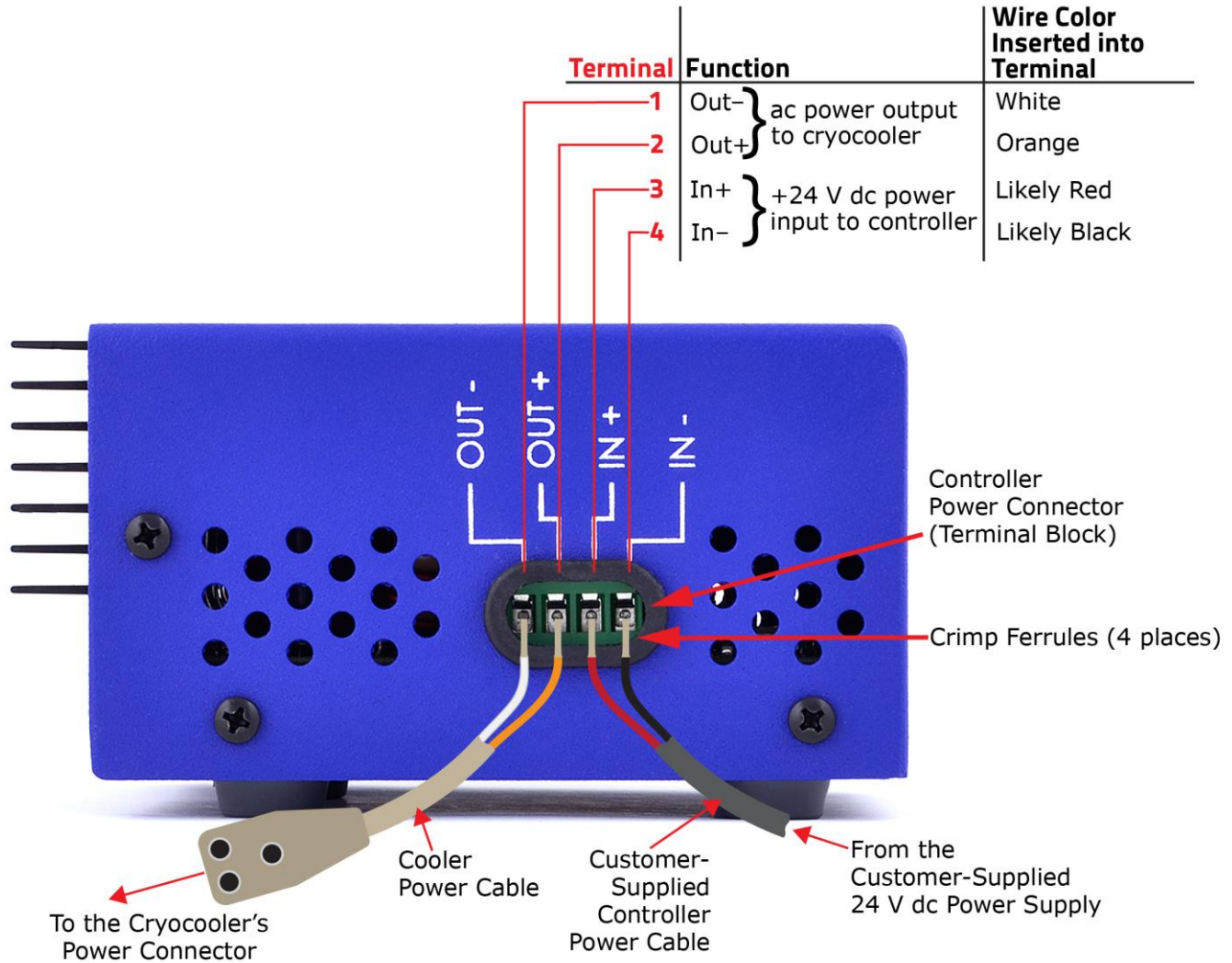

Figure 3-12. Controller Power Connector (Terminal Block)

## Install & Configure Terminal Emulation Software

If you don't already have terminal emulation software (such as PuTTY) installed on the computer connected to the controller, then download, install, and configure the software. This section contains general instructions for downloading, installing, and configuring PuTTY (a free terminal emulation program).

**Important** – The following steps are to be done with the controller power cable disconnected from the power supply and the cooler power cable disconnected from the controller.

### To Download, Install, & Configure PuTTY:

1. Download the latest release version of the PuTTY terminal emulation software and its Help file from [www.putty.org](http://www.putty.org).
2. In Windows®, click on the Start button, and choose Control Panel>All Control Panel Items>Device Manager.
3. In Device Manager, open the Ports (COM & LPT) device and make note of what COM port number is assigned to the port into which the serial communications cable is plugged. In the example in figure 3-13, it is COM4.

4. Launch PuTTY.exe.

PuTTY's Session Configuration Panel is displayed (figure 3-14).

5. Follow the steps on figure 3-14.

PuTTY's Serial Configuration Panel is displayed (figure 3-15).

6. Type in the numbers and select the options shown in figure 3-15 for the serial connection to the controller.

7. Click on the Open button.

A connection window (figure 3-16) will open. This is the window into which you will type in commands to send to the controller, and the window in which responses from the controller are displayed. The window will not work until power is supplied to the controller in the next section.

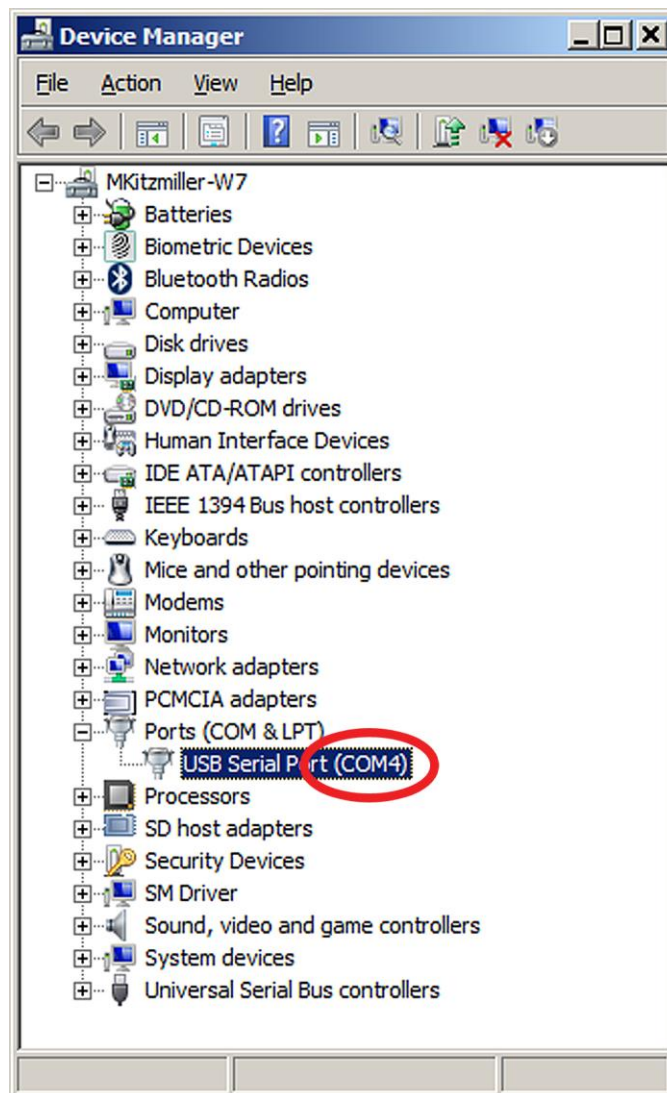
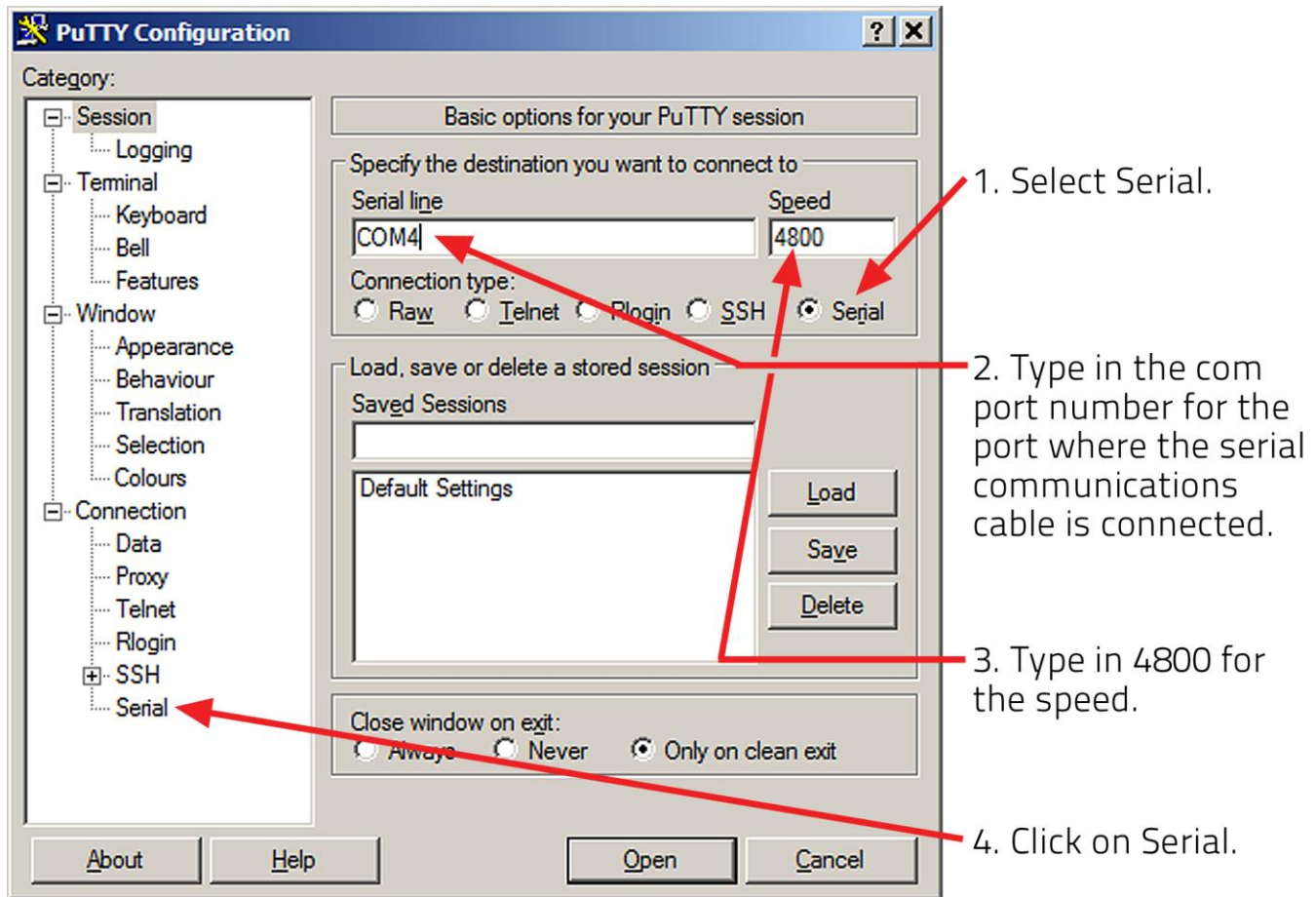

Figure 3-13. Identify What COM port is Assigned to the Controller

**Figure 3-14. PuTTY's Session Configuration Panel**

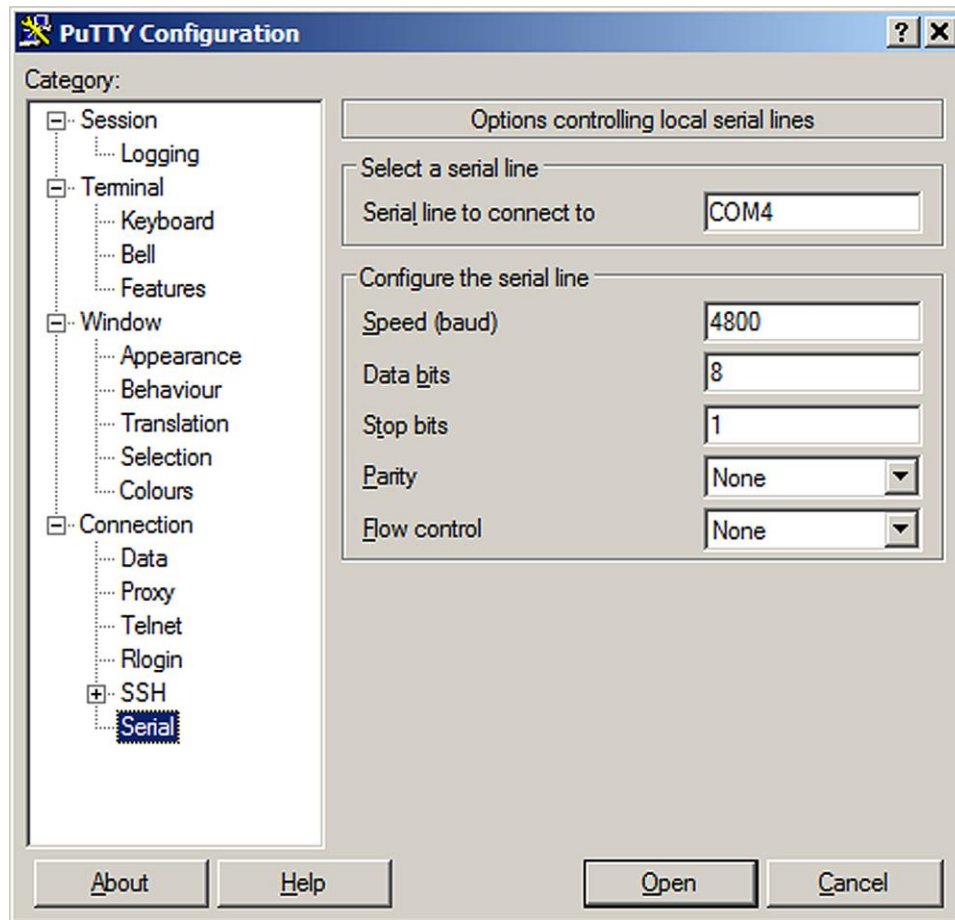

Figure 3-15. PuTTY's Serial Configuration Panel

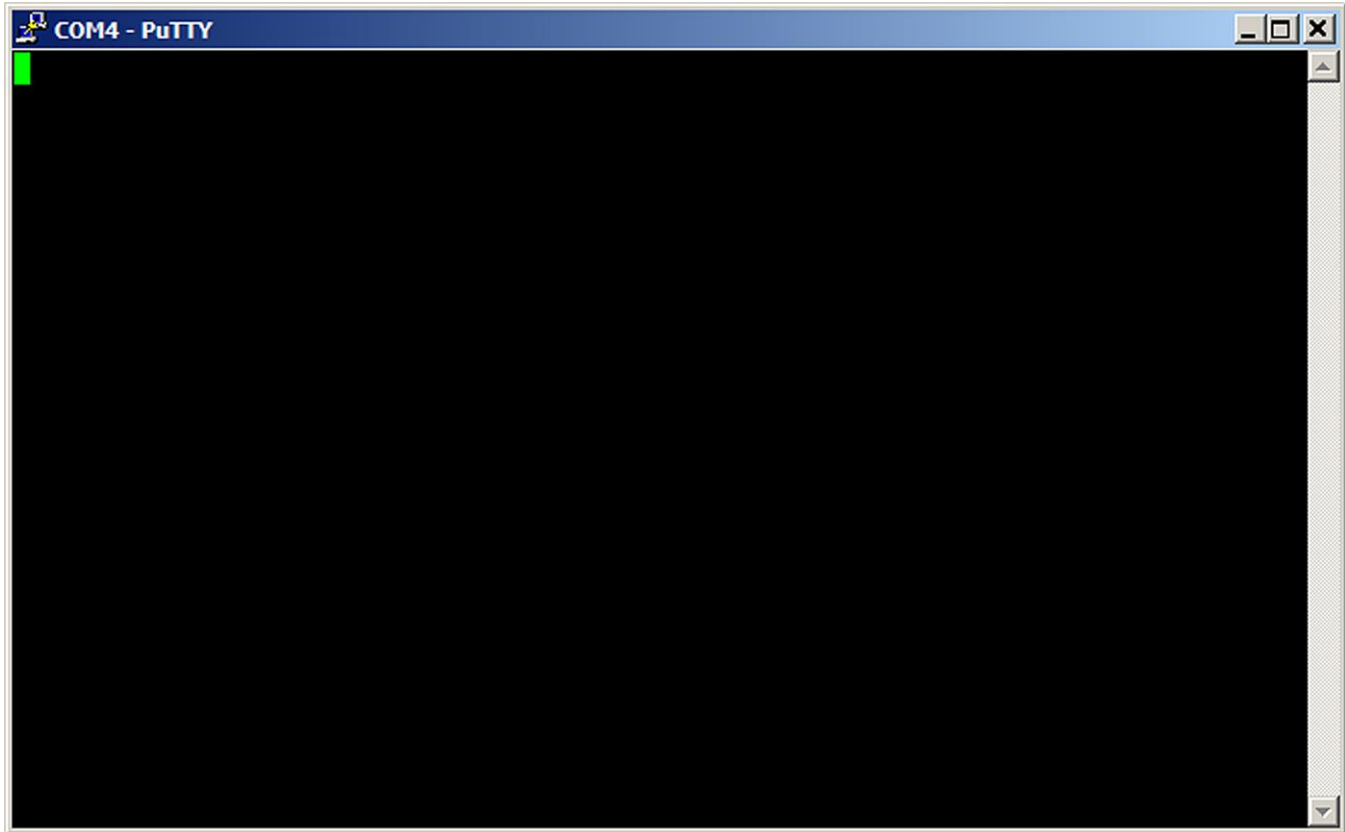

Figure 3-16. PuTTY's Open Session Screen

## Power Up the Controller

For this section, the controller end of the customer-supplied controller power cable should already be attached to the controller and the controller end of the cooler power cable should already be disconnected from the controller.

### To Power Up the Controller:

1. Connect the power supply end of the customer-supplied controller power cable to the customer-supplied 24 V dc power supply.
2. Ensure that the power supply is connected to its power source.
3. Turn on the power supply if it has an on-off power switch.

## Verify Proper Communications Between the PC & the Controller

Before connecting power to the cryocooler for the first time in the Startup section of chapter 4, you must first ensure that the terminal emulation software on the PC can communicate properly with the controller. This section lists the general instructions for ensuring proper communication.

**Important** – The following steps are to be done with the customer-supplied controller power cable connected between the controller and the power supply, and the controller end of the cooler power cable disconnected from the controller.

**To Verify Proper Communications:**

1. If not already running and configured, launch the terminal emulation software, and using the software's interface, open a serial connection to the COM port to which the controller is connected. (See the Install & Configure Terminal Emulation Software section.)
2. Cycle power to the controller either by disconnecting and reconnecting the controller's power cable or the power supply's power cable, or by using the on/off power switch on the power supply if it has one.

The following reply from the controller should be displayed in the terminal emulator's window:

```
*** 2nd Generation CryoCooler 2.0.0 ***
```

where 2.0.0 is the controller's software version number.

3. Type a command such as **TC** (the "Display Cold-Tip Temperature" command) into the terminal emulator's window and press the Enter key to make sure the serial communications are working.  
An appropriate reply from the controller should be displayed in the terminal emulator's window. (If you typed **TC**, the current temperature of the cold tip [RTD] in kelvins should be displayed in the terminal emulator's window.)
4. Shut off power to the controller either by disconnecting the controller's power cable or the power supply's power cable, or by using the on/off power switch on the power supply if it has one.  
The CryoTel CT system is now set up and ready to be started up using the start-up procedures in chapter 4.



# Chapter 4

## Operating Instructions

### Introduction















Before starting up and operating the CryoTel® CT system for the first time, ensure that it has been installed and set up properly as outlined in chapter 3. We also recommend that before starting up and operating the Cryotel CT system for the first time that you watch the operating videos that Sunpower will be posting on our website.

### Controls & Indicators

Neither the controller nor the CT cryocooler has a power switch or any other operator controls; the controller begins its start-up sequence as soon as power is applied to its power input terminals. Once the start-up sequence is completed, the controller operates the CT cryocooler based on the preferences set in the controller through commands from the user's computer.

The only indicators on the CryoTel CT system are the two status LEDs, one green and one red, on the front of the controller. Table 4-1 lists the LED states that may occur and their meaning. Table 4-2 identifies the errors indicated by the LED flashes described in row four of table 4-1.

**Table 4-1. LED Legend**

LED State Description	Meaning
 Both LEDs are lit and steady. 	The controller is starting up.
 The green LED is off.  The red LED is lit and steady.	In the temperature control mode, this means that the cryocooler cold tip is not within the set $\pm$ temperature band centered on the target temperature*, and hence the Digital Out 4 pin on the controller's I/O connector will be low (0 V). In the power control mode, this means that the cryocooler is not running.
 The green LED is lit and steady.  The red LED is off.	In the temperature control mode, this means that the cryocooler cold tip is within the set $\pm$ temperature band centered on the target temperature*, and hence the Digital Out 4 pin on the controller's I/O connector will be high (5 V). In the power control mode, this means that the cryocooler is running.
 The green and red LEDs are flashing in unison in a repeating series of flashes consisting of short flashes and a long flash. 	At least one error has occurred. The combined number of short flashes plus the long flash in the series identifies the error that has occurred as defined in table 4-2. If more than one error has occurred, this series of flashes is followed by the <b>Rapid Alternate Flashing</b> state described in the next row of this table.
  The LEDs are alternately flashing between green and red rapidly, or very slowly.   	<p><b>Rapid Alternate Flashing:</b> More than one error has occurred. (To find out what other errors are occurring, use the <b>ERROR</b> command in the terminal emulator program.)</p> <p><b>Very Slow Alternate Flashing:</b> Soft-stop shutdown has been initiated so the cryocooler is being slowed down and the piston parked.</p>
 Both LEDs are off. 	Electrical input power to the controller has been turned off or disconnected from the controller.

\*The target temperature can be set using the **SET TTARGET=<Value>** command.  
 The  $\pm$  temperature band can be set using the **SET TBAND=<Value>** command.

**Table 4-2. Errors Indicated by the Simultaneous LED Flashes**

Number of LED Flashes*	Name of the Error Indicated**
1	Over Current
2	FET Driver Error
3	Serial Communications Error
4	Non-Volatile Memory Error
5	Watchdog Error
6	Temperature Sensor Error

\*This number includes the short flashes and the final long flash.

\*\* Refer to the Troubleshooting section in Chapter 5 for more information on these errors.

## Operating Modes

The controller operates the CT cryocooler in one of two modes: temperature control mode, or power control mode. The temperature control mode is the factory default operating mode with a factory default target temperature of 77 K.

### Temperature Control Mode

In temperature control mode, the controller increases or decreases the electrical power to the cryocooler as needed to keep the temperature of the cold tip at the user-defined target temperature (as set by the **SET TTARGET=<Value>** command). The controller reads the temperature of the cold tip from the RTD that is installed on or near the cold tip.

### Power Control Mode

In the power control mode, the controller provides power to the cryocooler at the target power output level set by the user (using the **SET PWOUT=<Value>** command) as long as the target power output level is within the currently-calculated allowable operating power range of the cryocooler as shown using the **E** command. Refer to the **E** command section in appendix B for details on how this range is calculated. In this mode, the controller does not attempt to maintain the cold tip at any target temperature.

## Startup

Before starting up and operating the CryoTel CT system, ensure that it has been installed and set up properly as outlined in chapter 3. The configuration of the system after setup and prior to startup includes three cables connected to the controller (the RTD cable, the RS-232 serial communications cable, and the controller power cable), the serial cable connected to the PC, and the RTD in place and connected to the RTD cable, but the controller end of the cooler power cable disconnected from the controller (on initial startup only), and the power supply end of the controller power cable either disconnected from the power supply or the power supply turned off. The terminal emulation program should have already been configured and should be open and running on the PC.

## Connect the Cooler Power Cable to the Controller

Figure 3-12 shows the function and layout of the terminals on the power connector (terminal block) on the side of the controller. This is where the controller end of the cooler power cable is connected.

### To Connect the Cooler Power Cable to the Controller:

**Caution** – When connecting the cooler power cable leads to the controller, verify that the correct polarity is observed. Reversed polarity could result in damage to the cryocooler upon startup.

1. Insert the white wire on the end of the cooler power cable into the “OUT–” terminal inside the power connector (terminal block) opening on the side of the controller.
2. Insert the orange wire on the end of the cooler power cable into the “OUT+” terminal inside the power connector (terminal block) opening on the side of the controller.
3. Insert the end of a small flat-head screwdriver into the screw access slots on the top of the controller and tighten the two terminal block screws onto the orange and white wires of the cooler power cable.

## Ensure Proper Connection to the Supply

See Chapter 3 Connection to the supply (page 3-17)

## Start up the CryoTel CT System

### To Start up the CryoTel CT System:

1. If using a vacuum, start the vacuum pump.

**Caution** – Do not operate the cryocooler without adequate cooling at the heat rejector. Overheating will cause permanent damage to the cryocooler.

2. (Optional) If using the optional pressure vessel water jacket and/or the heat rejector water jacket, do the following.
  - a. Ensure that air is removed from the water jacket by flowing water through the cooling system for several minutes.
  - b. If it appears that air is still trapped in the water jacket, try carefully tilting the cooler in the direction away from the cooler discharge tube.  
This will raise the level of the discharge tube and allow any trapped air to escape.  
Trapped air will decrease heat rejection and cooler performance.  
Water should be flowing through the jacket at approximately 15 mL per second (0.24 gallons per minute).
3. (Optional) If using the optional air fins, turn on the fan and any other equipment associated with your forced-air cooling system.

The minimum airflow required to maintain proper cooling is 100 cfm (2.83 m<sup>3</sup>/min).

**Caution** – When the cryocooler is not in operation, a cold tip temperature up to 360 K (87 °C) is permissible, but do not operate the cryocooler unless the cold tip temperature has dropped below 310 K (37 °C) or you risk damage to the cryocooler. (If you’re using a heater on the cold tip, make sure to shut it off when the cold tip reaches 300 K.)

**Caution** – Do not control power to the cryocooler by making or breaking the power leads between the controller and the cryocooler because the controller needs to run the cryocooler through a start-up sequence before it begins normal operation.

4. Ensure that the customer-supplied controller power cable is connected between controller and the customer-supplied 24 V dc power supply, and that the power supply is connected to its power source; then turn on the power supply if it has an on-off power switch.

The controller will immediately begin its startup sequence which lasts 7 to 10 seconds.

The following reply from the controller should be displayed in the terminal emulation window:

```
*** 2nd Generation CryoCooler 2.0.0 ***
```

where 2.0.0 is the controller's software version number.

The controller then applies an AC voltage to the cryocooler causing the piston to move back and forth, which in turn begins the cooling process.

Assuming the controller is set to temperature control mode, the controller will apply the proper amount of electrical power to the cryocooler based on the target temperature setting and the cold tip temperature read from the RTD.

**Important** – If the cryocooler does not start up, the controller's soft-stop state may have been set to 1, thereby preventing the cryocooler from starting up. (To check the soft-stop state, enter the **SET SSTOP** command into the terminal emulator program on your computer to display the controller's soft-stop state. If the soft-stop state is set to 1, then use the **SET SSTOP=0** command to start up the cryocooler.)

5. Enter the **TC** command into the terminal emulator program periodically during the cool-down period to monitor the decreasing temperature of the cold tip.

The resulting temperature reading should stabilize at the target temperature. The default target temperature is 77 K. (Use the **SET TTARGET** command to display the target temperature. Use the **SET TTARGET=<Value>** command to change the target temperature.)

Proper operation of the CT cryocooler requires a minimum input power of 60 W which equates to a thermal load of about 4 W @ 77 K. If this minimum load requirement is not met, the stabilized cold tip temperature will be below the target temperature.

## Operating Tasks

Once the CT has been started up, its operation is essentially automatic. This section lists some of the more common tasks that can be performed during operation. All these tasks involve sending commands to the controller via the terminal emulation program on your computer. Appendix B contains a complete listing of all the possible commands that you can send to the controller. The appendix also includes command descriptions and examples.

The following conventions are used in this section:

- “<CR>” is a symbol used to represent the carriage return character. The controller requires the carriage return character at the end of each command. In the examples in this section, “<CR>” is used to emphasize this requirement and to mean “press the Enter key”. (Pressing the Enter key sends the carriage return character and a line feed character to the terminal emulator program, which only sends the carriage return character to the controller.)
- “<Value>” means “type the value that you want the command to use”.
- The first line in the examples' computer display box is what is shown on the display as you type, before you press the Enter key. The second line is the information returned from the controller after you press the Enter key.

## Display Cold-Tip Temperature

Use the **TC** command to display the current temperature of the cold tip in kelvins, or more specifically, the temperature that the controller calculates based on the resistance it detects across the RTD leads.

**Example:**

You type: **TC<CR>**

The computer displays: **TC  
295.21**

The **295.21** returned in this example indicates that the cold tip temperature is 295.21 K.

## Display Target Temperature

Use the **SET TTARGET** command to display the target cold tip temperature that the controller will try to make the cryocooler attain,  $\pm 0.1$  K, when the controller is in temperature control mode. The default target temperature is 77 K. (You can use the **SET TTARGET=<Value>** command to change the target temperature.)

**Example:**

You type: **SET TTARGET<CR>**

The computer displays: **SET TTARGET  
077.00**

The **077.00** returned in this example indicates that the target temperature setting is 77 K.

## Set Target Temperature

Use the **SET TTARGET=<Value>** command to change the target cold tip temperature that the controller will try to attain,  $\pm 0.1$  K, when the controller is in temperature control mode. The default target temperature is 77 K.

**Example:**

You type: **SET TTARGET=86<CR>**

The computer displays: **SET TTARGET=86  
086.00**

The **086.00** returned in this example indicates that the target temperature setting is 86 K. If the controller is in temperature control mode, then the controller will adjust the power to the cryocooler as needed to try to attain a cold tip temperature of 86 K  $\pm 0.1$  K.

## Shutdown

There are two methods of shutting down the CryoTel CT system: the soft-stop method (recommended), and the “remove power from the controller” method (alternate). In the soft-stop method, the controller first ramps down power to the cryocooler, parks the piston, then removes power from the cryocooler. Once that occurs, the user may remove power from the controller, or keep it on. In the “remove power from the controller” method, the user removes power from the controller which results in the immediate removal of power from the cryocooler.

**Caution** – Do not cut off power to the cryocooler by breaking the power leads between the controller and the cryocooler.

**Caution** – If operating below 77 K, we recommend you use a heater to heat the cold tip after operation has stopped to avoid possible spontaneous self-excitation of the cryocooler and possible subsequent damage. Contact Sunpower for more information.

**Caution** – If using an optional heater to heat the cold tip after power has been disconnected from the controller, the cold tip temperature must be monitored by an additional sensor. When the cold tip reaches 300 K, the heater power must be removed.

### Soft-Stop Shutdown Method (Recommended)

This section describes the recommended method of shutting down the CryoTel CT system. This method uses the soft-stop command **SET SSTOP=1** to slowly ramp down the cryocooler, park the piston, and stop the cryocooler before the user turns off or disconnects the customer-supplied 24 V dc power supply. This method minimizes vibration. It also allows the controller to remain on while the cryocooler's cold tip temperature increases so that the controller can be used to monitor the cold tip temperature as it rises to room temperature.

**Note** – If you use this soft-stop method of shutting down the system, the controller will retain the **SSTOP=1** state so that the next time you power on the controller, it will not start up the cryocooler until you change the soft-stop state back to 0.

#### To Shut Down the System Using the Soft-Stop Shutdown Method (Recommended):

1. Enter the **SET SSTOP=1** command into the terminal emulator program.

The controller will slowly ramp down the cryocooler, park the piston, and stop the cryocooler. During the soft stop, the cold tip temperature will begin to increase. The controller will remain on so that you can monitor the cold tip temperature (using the **TC** command) or issue other commands.

2. (Optional) Turn off or disconnect the customer-supplied 24 V dc power supply from its power source, or if that is not possible, disconnect the customer-supplied controller power cable from the power supply.

The controller will turn off.

3. If using an active cooling system to cool the CT's heat rejector, then turn off that system.
4. If using a vacuum, stop the vacuum pump and open the vacuum.
5. If using a heater on the cold tip (optional), then turn it off when the cold tip temperature reaches 300 K.

### Alternate Shutdown Method

This section describes an alternate method of shutting down the CryoTel CT system, which is to remove power from the controller by turning off or disconnecting the customer-supplied 24 V dc power supply. This in turn removes power from the cryocooler.

#### To Shut Down the System Using the Alternate Shutdown Method:

1. Turn off or disconnect the customer-supplied 24 V dc power supply from its power source, or if that is not possible, disconnect the customer-supplied controller power cable from the power supply.

The controller will turn off, which in turn, will cut off power to the cryocooler. The cryocooler's piston will stop moving and the cold tip temperature will begin to increase.

2. If using an active cooling system to cool the CT's heat rejector, then turn off that system.
3. If using a vacuum, stop the vacuum pump and open the vacuum.
4. If using a heater on the cold tip (optional), then turn it off when the cold tip temperature reaches 300 K.

# Chapter 5

## Maintenance and Inspection

### Directions for Cleaning

Prior to cleaning, the cryocooler and controller must be powered off and the input power cable connecting the controller to the power supply must be disconnected. The cryocooler should be allowed to return to room temperature.

All of the Warnings and Cautions in Chapters 3 and 4 must be much be followed.

The cryocooler and/or Generation II controller can be cleaned by adding small amount of isopropyl alcohol directly to a rag and lightly rubbing the surface of the cryocooler or case of the controller.

### Maintenance and Inspection Precautions

Prior to any maintenance or inspection the cryocooler and controller must be powered off, and the input power cable connecting the controller to the power supply must be disconnected. The cryocooler should be allowed to return to room temperature.

All of the Warnings and Cautions in Chapters 3 and 4 must be much be followed.

Following any maintenance or inspection, the cryocooler and controller should be checked to ensure they are set up according to Chapter 3. The Startup instruction in Chapter 4 should be followed prior to running the system.

Service personnel should be cautious of the cryocooler rolling, which could cause it to fall and cause injury.

Integration into customer systems including but not limited to dewars, mounting hardware, and wiring could cause further risks. In larger systems the cryocooler and controller must be kept within the rated ambient conditions or further hazards could be created

### User-Level Maintenance and Inspection

There are no user-level maintenance tasks required for the basic cryocooler or the controller. The CT's moving parts (except for the passive balancer) are enclosed inside the welded pressure vessel. The controller is also self-contained and has no moving parts.

If you have the optional, removable water jacket or removable air fins for the heat rejector, then the thermal grease used between the water jacket or air fins and the heat rejector should be refreshed periodically because it will dry out over time.

If you have the optional air fins installed in an open atmosphere environment, they you should clean the fins periodically to remove any dust or debris that may have accumulated in or around the fins.

If you have an optional removable NW50 vacuum flange, you may have to eventually replace the internal O-ring if the flange is repeatedly removed and reinstalled over time. The O-ring is a Parker type S1138 2-032 Silicone O-ring with an inner diameter of 1.864 inches and a width of 0.07 inches.

No other maintenance is necessary. If service is required, all parts not mentioned above are required to be examined or supplied by Sunpower, Inc."

# Chapter 6

## Troubleshooting

### Troubleshooting

Table 5-1 lists some problems/error conditions that may occur, their possible causes, and what to do if they occur. If you can't resolve a problem after looking at the chart, contact Sunpower at [info@sunpowerinc.com](mailto:info@sunpowerinc.com) or call us at (740)594-2221. Before contacting Sunpower, if possible, run the **STATE** command and record the results. This information may help Sunpower's engineering personnel to more quickly resolve the problem.

**Table 5-1. Troubleshooting Chart**

Symptom/Error Condition	Possible Causes	Actions
Cold tip temperature is fluctuating or is erratic.	Electrical noise on the RTD cable	Ground the shield on the shielded RTD cable to the controller. If possible, attach the other end of the shield to the cryocooler body or to the cryostat structure. There is not a dedicated pin on the controller's TEMP connector for connecting the shield, but you can connect the shield to the I- wire at pin 4 of the connector on the RTD cable.
	Faulty RTD wiring	Check for any broken, shorted, or disconnected RTD wires, RTD cable wires, or connectors between the controller and the RTD including the fine wires attached to the RTD itself.
	RTD failure	Test the RTD using the steps in the <i>Test the RTD</i> section at the end of this chapter. If the test points to a defective RTD, then replace the RTD.
Pressure vessel is hot to the touch.	Normal operation	The cryocooler can operate indefinitely with the pressure vessel at 80 °C or below without damaging the cryocooler; however, performance of the cryocooler will be affected by temperatures over 80 °C and damage may occur. In this case, we recommend that you provide some form of cooling such as air or water circulation or solid conduction for the pressure vessel. Contact Sunpower's engineering department at <a href="mailto:info@sunpowerinc.com">info@sunpowerinc.com</a> for ideas on removing heat from the cryocooler.

(continues on next page)

**Table 5-1. Troubleshooting Chart (continued)**

Symptom/Error Condition	Possible Causes	Actions
Cryocooler does not start up after power is applied to the controller.	Soft-stop state is set to 1 (“enabled”).	Use the <b>SET SSTOP</b> command to display the soft-stop state. <ul style="list-style-type: none"> <li>• If the returned value is 1, then start up the cryocooler using the <b>SET SSTOP=0</b> command.</li> <li>• If the returned value is 0, then the problem lies elsewhere.</li> </ul>
	Faulty power cables or connectors	Check for any broken, shorted, or disconnected power wires, power cables, or connectors between the cryocooler, the controller, and the power supply.
Cold tip temperature doesn’t seem correct.	Faulty RTD wiring	Check for any broken, shorted, or disconnected RTD wires, RTD cable wires, or connectors between the controller and the RTD including the fine wires attached to the RTD itself.
	Using the wrong temperature sensor	Check that you’re using the correct temperature sensor: a Lake Shore model PT-111 platinum resistance thermometer, part of the custom RTD that was shipped with the CT system.
	RTD failure	Test the RTD using the steps in the <i>Test the RTD</i> section at the end of this chapter. If the test points to a defective RTD, then replace the RTD.
Cold tip is not maintaining the target temperature. (The cold tip is too cold.)	Not enough thermal load on the cold tip	The cryocooler has a minimum power operating threshold (figure 2-6). The controller establishes the minimum level and will not allow the cryocooler to operate below that point. This is necessary in order to maintain the gas bearing system that is used for the moving parts. If the minimum cooling power (lift) of the cryocooler at the target temperature is greater than the thermal load, then the cryocooler system will not be able to maintain the target temperature. The cold tip temperature will drift down until equilibrium is reached between the thermal load and the cryocooler lift. In this situation, you could install a small resistive heater on or near the cold tip to compensate, or increase your thermal load. (This problem, however, may indicate that a less powerful cooler might be more appropriate for your application.)
Cryocooler body or heat rejector temperature is greater than 80 °C.	Inadequate heat rejection	Increase the cooling of the heat rejector.
Can’t change controller parameters in the terminal emulation program.	User-lockable commands are locked.	Unlock the user-lockable commands using the <b>UNLOCK=&lt;Password&gt;</b> command.
	Loss of communication between	Verify proper communications between the computer & controller (page 3-22).

	computer and controller	
--	-------------------------	--

(continues on next page)

**Table 5-1. Troubleshooting Chart (continued)**

Symptom/Error Condition	Possible Causes	Actions
Error Code 000001 or 1 flash of the LEDs*	<b>Overcurrent</b>	If the controller detects an overcurrent, it will immediately shut off power to the cryocooler. Check for any broken, shorted, or disconnected wires, cables, or connectors between the controller and the cryocooler.
Error Code 000010 or 2 flashes of the LEDs*	<b>Jumper Error</b>	Power cycle the controller.
Error Code 000100 or 3 flashes of the LEDs*	<b>Serial Communication Error</b>	Communication with the controller may not be possible after a serial communication error. Power cycle the controller.
Error Code 001000 or 4 flashes of the LEDs*	<b>Non-Volatile Memory Error</b>	Power cycle the controller.
Error Code 010000 or 5 flashes of the LEDs*	<b>Watchdog Error</b>	Power cycle the controller.
Error Code 100000 or 6 flashes of the LEDs*	<b>Temperature Sensor Error</b>	<ol style="list-style-type: none"> <li>1. Check for any broken, shorted, or disconnected RTD wires, RTD cable wires, or connectors between the controller and the RTD including the fine wires attached to the RTD itself.</li> <li>2. Check to see if the controller is reporting an appropriate temperature; if not, do one or both of the following: <ul style="list-style-type: none"> <li>• Check that you're using the correct temperature sensor: a Lake Shore model PT-111 platinum resistance thermometer, part of the custom RTD that was shipped with the CT system.</li> <li>• Test the RTD using the steps in the <i>Test the RTD</i> section at the end of this chapter. If the test points to a defective RTD, then replace the RTD.</li> </ul> </li> </ol> <p>If the RTD has intermittent problems, the error code will remain in the controller even if the wiring starts functioning properly again. The controller must be power cycled to clear the error code.</p>
Both LEDs are off.	Customer-supplied power supply is turned off or disconnected.	Check to make sure the power supply is turned on, connected to a power source, and connected to the controller.
	Faulty power cable or connectors	Check for any broken, shorted, or disconnected power wires or connectors between the controller and the power supply.

	Faulty power supply	Check for proper power output from the power supply.
	Faulty controller	Power cycle the controller.

\*The number of flashes includes the short flashes plus the final long flash.

## Test the RTD

To test the RTD after it has been installed, you'll have to isolate it from any elements that might affect the test.

**Caution** – The RTD is an Electrostatic-Sensitive Device (ESD). Use ESD precautionary procedures, tools, and equipment such as grounding straps, grounding mats, grounding tools, antistatic garments, etc. when handling or making mechanical or electrical connections to this device in order to avoid performance degradation or loss of functionality.

### To Test the RTD:

1. Place the RTD in a room, enclosure, or area in which the ambient temperature is 20 °C and wait a few minutes for the RTD to adjust to the temperature.
2. Measure the resistance across the V+ (Black) lead and the V- (Green) lead, or across the I+ (Clear) lead and the I- (Red) lead (figure 5-1).

The resistance should be 100–110 Ω; if it isn't, the RTD is likely defective.

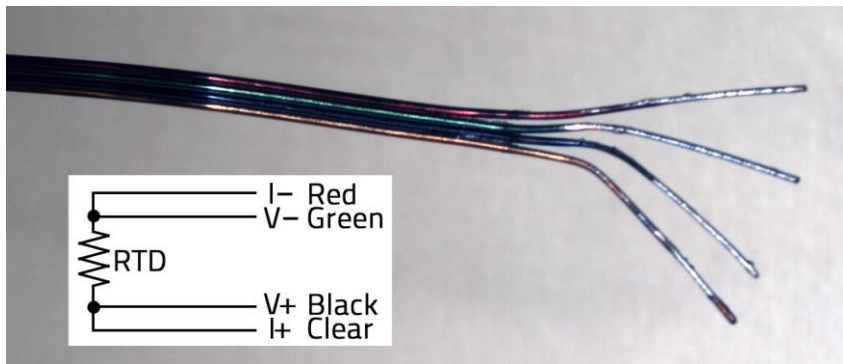

Figure 5-1. The Four Leads of the RTD Wire



# Appendix A

## Exported Vibration Test Results

### Exported Vibration Test Summary

Exported Vibration refers to the vibration produced by the cryocooler. This information is important for applications that are sensitive to vibration, such as optics. This information should make it easier for you to integrate the cryocooler into your application.

This appendix includes the results of three tests (suspended orientation, soft mount, and hard mount) that were run on several CryoTel® CT cryocoolers at Sunpower in June of 2013 using a CryoTel Generation II controller. Each cryocooler was fitted with a standard, single (60 Hz), passive balancer. All tests were performed with full power (160 W) to the cryocooler.

Figure A-1 shows the x-, y-, and z-axes orientation, relative to the cryocooler, that was used in reporting the results.

For the peak acceleration charts in this appendix, the acceleration is measured in thousands of a g (milli-g, or just mg) where g is the standard value of gravitational acceleration (9.80665 m/s<sup>2</sup>).

For the peak force charts in this appendix, the force is measured in newtons (N).

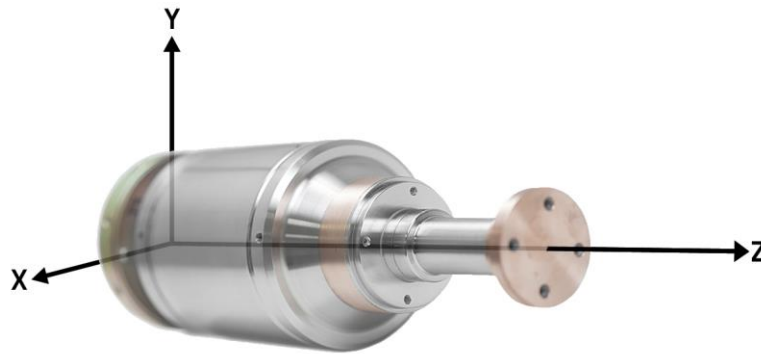

**Figure A-1. Axes Orientation**

## Suspended Orientation Test Setup

The cryocooler/Dewar assembly was suspended from the cryocooler test rig (figure A-2). The tethers supported the cryocooler/Dewar assembly, but were not attached to it via attachment points or an adhesive. An accelerometer (PCB Piezotronics 352C65) was attached to the top of the cryocooler using 5-minute epoxy.

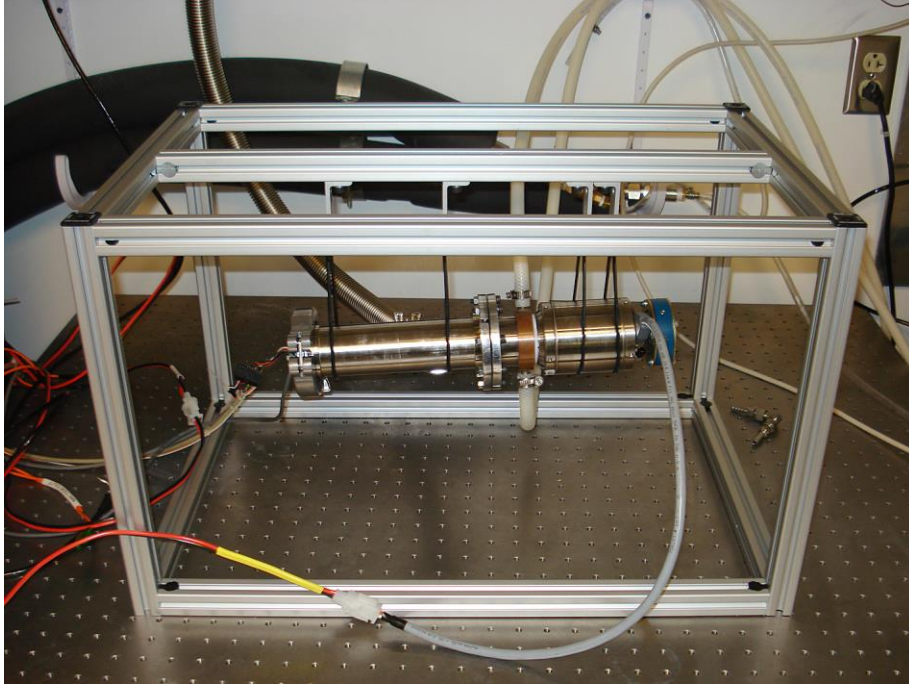
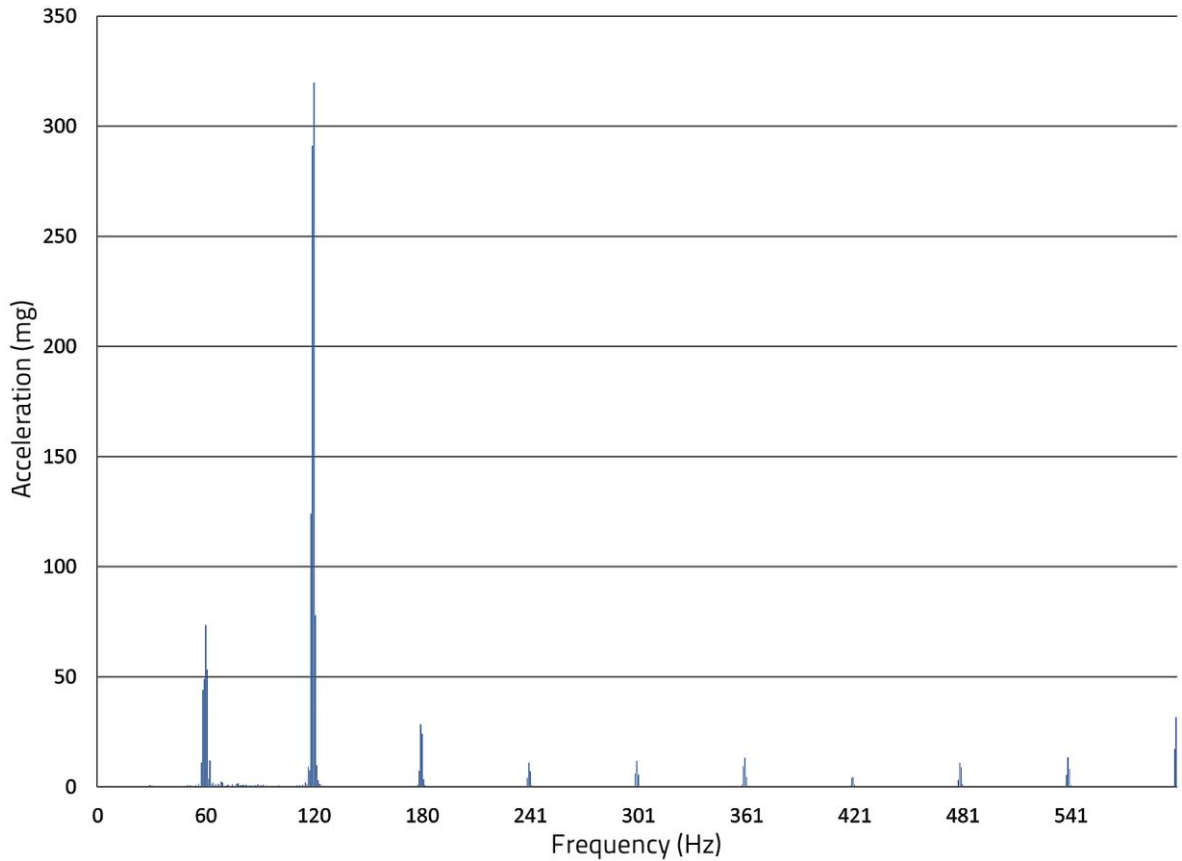

**Figure A-2. Test Setup for the Suspended Orientation Test**

## Suspended Orientation Test Results

Figure A-3 shows the average of the peak acceleration ( $A_z$ ) results for four cryocoolers tested in the suspended orientation. The x-axis of the chart shows the frequency spectrum of the vibrations recorded in the cryocooler's z-axis. The y-axis of the chart shows the average peak acceleration recorded in the cryocooler's z-axis at each frequency.

The Root Mean Square (RMS) of the acceleration results was calculated to be 36.48 mg, and the standard deviation was calculated to be 24.62 mg.



**Figure A-3. Average Peak Acceleration ( $A_z$ ) for the Suspended Orientation Test**

## Soft Mount Test Setup

The cryocooler/Dewar assembly was mounted to a dynamometer (Kistler 9272) which was mounted to an optical table via four rubber cushion mounts (McMaster Carr 96905K37) (vibration isolation bushings with a durometer hardness of 58A) (figure A-4). An accelerometer (PCB Piezotronics 352C65) was attached to the top of the cryocooler using 5-minute epoxy.



Figure A-4. Test Setup for the Soft Mount Test

## Soft Mount Test Results

Figure A-5 shows the average of the peak acceleration ( $A_z$ ) results for two cryocoolers tested in the soft mount configuration. The x-axis of the chart shows the frequency spectrum of the vibrations recorded in the cryocooler's z-axis. The y-axis of the chart shows the average peak acceleration recorded in the cryocooler's z-axis at each frequency.

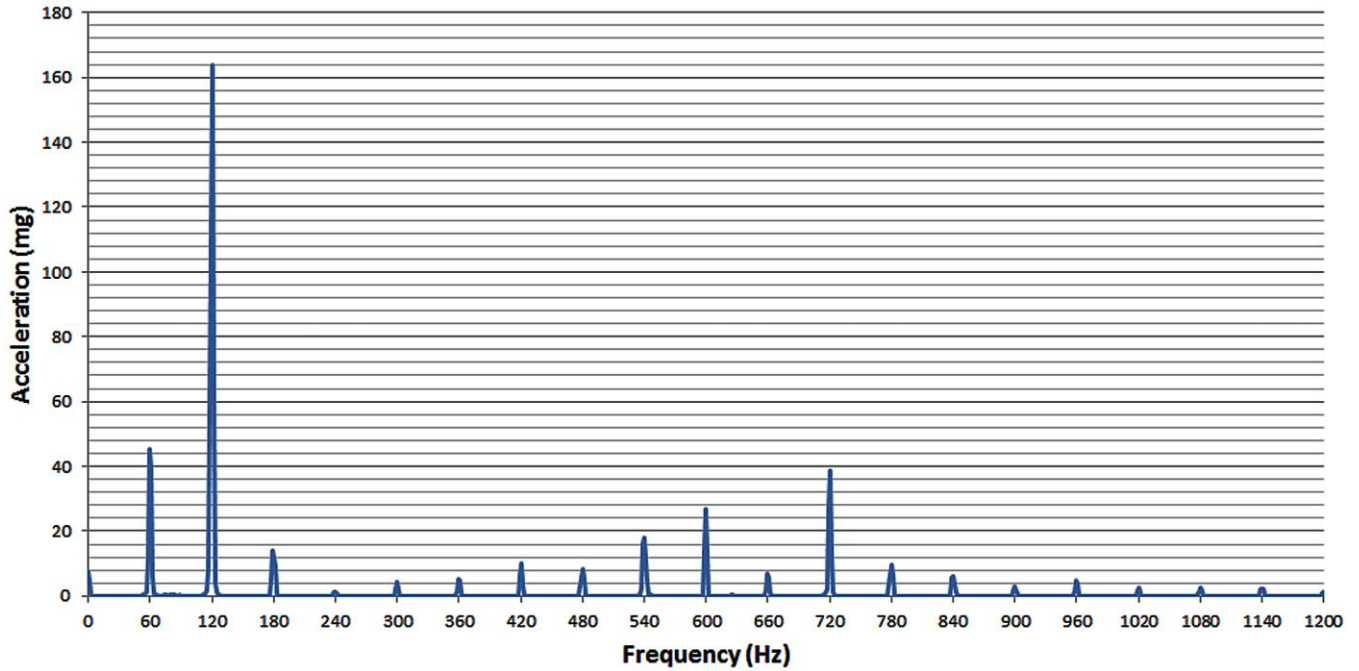

**Figure A-5. Average Peak Acceleration ( $A_z$ ) for the Soft Mount Test**

Figure A-6 shows the average of the peak force ( $F_x$ ) results for three cryocoolers tested in the soft mount configuration. The x-axis of the chart shows the frequency spectrum of the vibrations recorded in the cryocooler's x-axis. The y-axis of the chart show the average peak force recorded in the cryocooler's x-axis at each frequency.

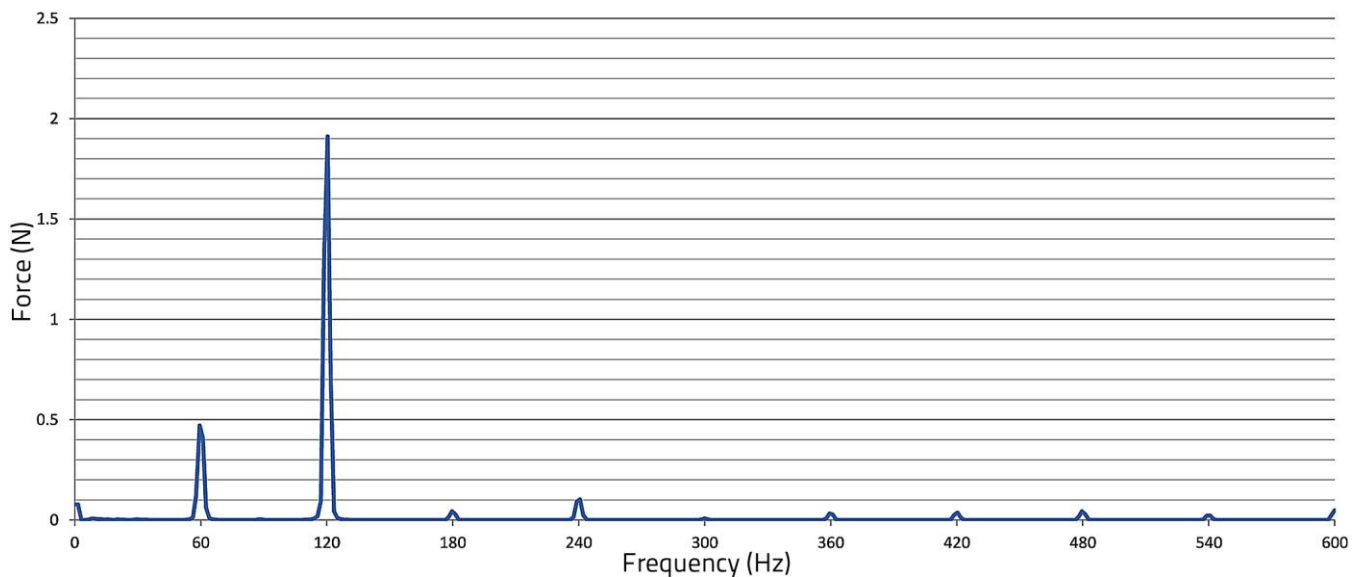

**Figure A-6. Average Peak Force ( $F_x$ ) for the Soft Mount Test**

Figure A-7 shows the average of the peak force ( $F_y$ ) results for three cryocoolers tested in the soft mount configuration. The x-axis of the chart shows the frequency spectrum of the vibrations recorded in the cryocooler’s y-axis. The y-axis of the chart show the average peak force recorded in the cryocooler’s y-axis at each frequency.

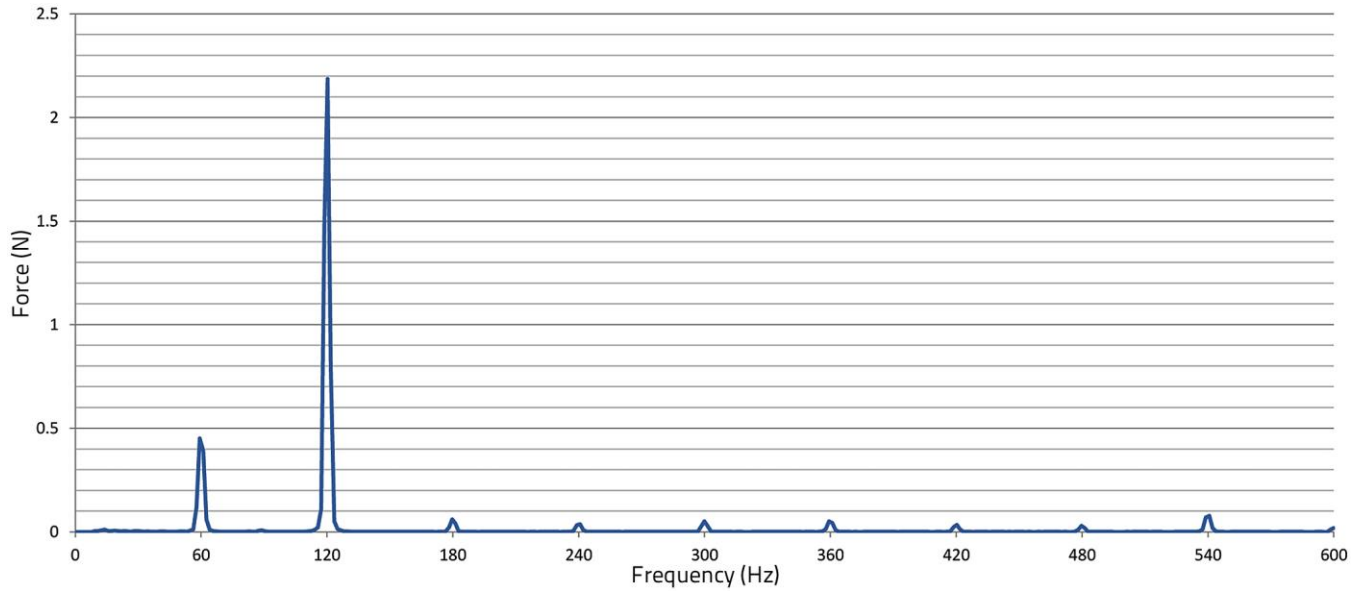

**Figure A-7. Average Peak Force ( $F_y$ ) for the Soft Mount Test**

Figure A-8 shows the average of the peak force ( $F_z$ ) results for three cryocoolers tested in the soft mount configuration. The x-axis of the chart shows the frequency spectrum of the vibrations recorded in the cryocooler’s z-axis. The y-axis of the chart show the average peak force recorded in the cryocooler’s z-axis at each frequency.

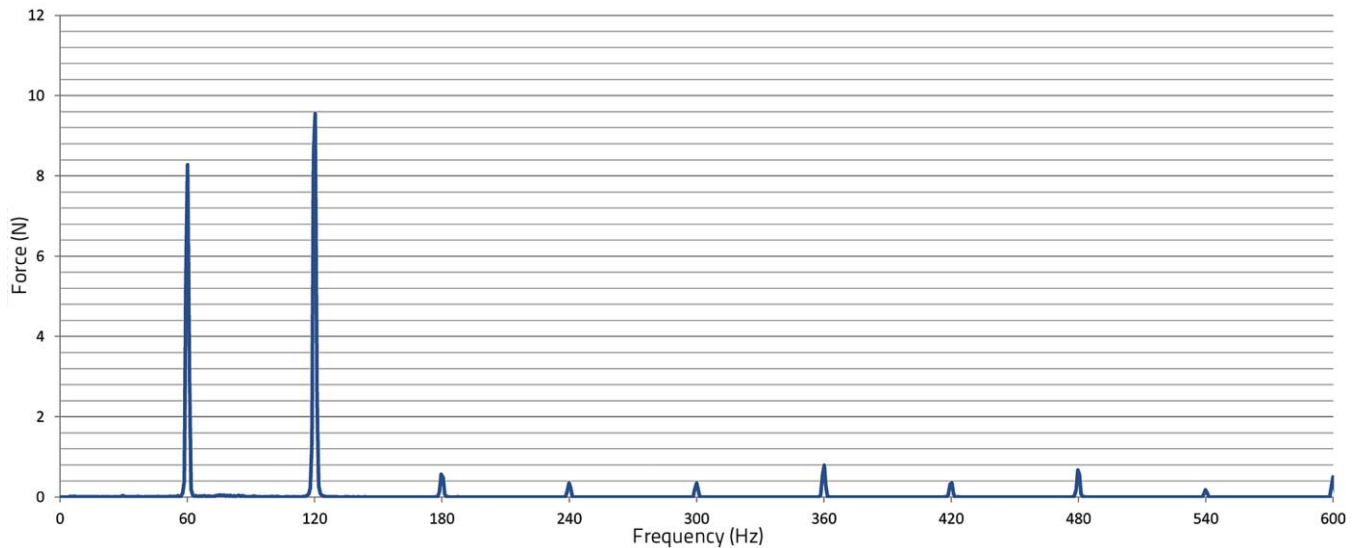

**Figure A-8. Average Peak Force ( $F_z$ ) for the Soft Mount Test**

## Soft Mount RMS Acceleration & Force

Table A-1 lists the Root Mean Square (RMS) of the peak acceleration and peak force results for the soft mount test.

**Table A-1. Soft Mount RMS Acceleration & Force**

Peak Acceleration or Peak Force	RMS Value
Az	25.28 mg
Fx	0.38 N
Fy	0.44 N
Fz	2.31 N

## Hard Mount Test Setup

The cryocooler/Dewar assembly was mounted to a dynamometer (Kistler 9272) which was bolted directly to an optical table (figure A-9). An accelerometer (PCB Piezotronics 352C65) was attached to the top of the cryocooler using 5-minute epoxy.

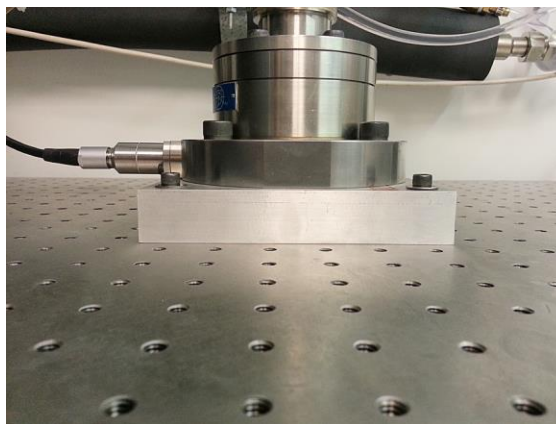

**Figure A-9. Test Setup for the Hard Mount Test**

## Hard Mount Test Results

Figure A-10 shows the average of the peak acceleration ( $A_z$ ) results for four cryocoolers tested in the hard mount configuration. The x-axis of the chart shows the frequency spectrum of the vibrations recorded in the cryocooler's z-axis. The y-axis of the chart shows the average peak acceleration recorded in the cryocooler's z-axis at each frequency.

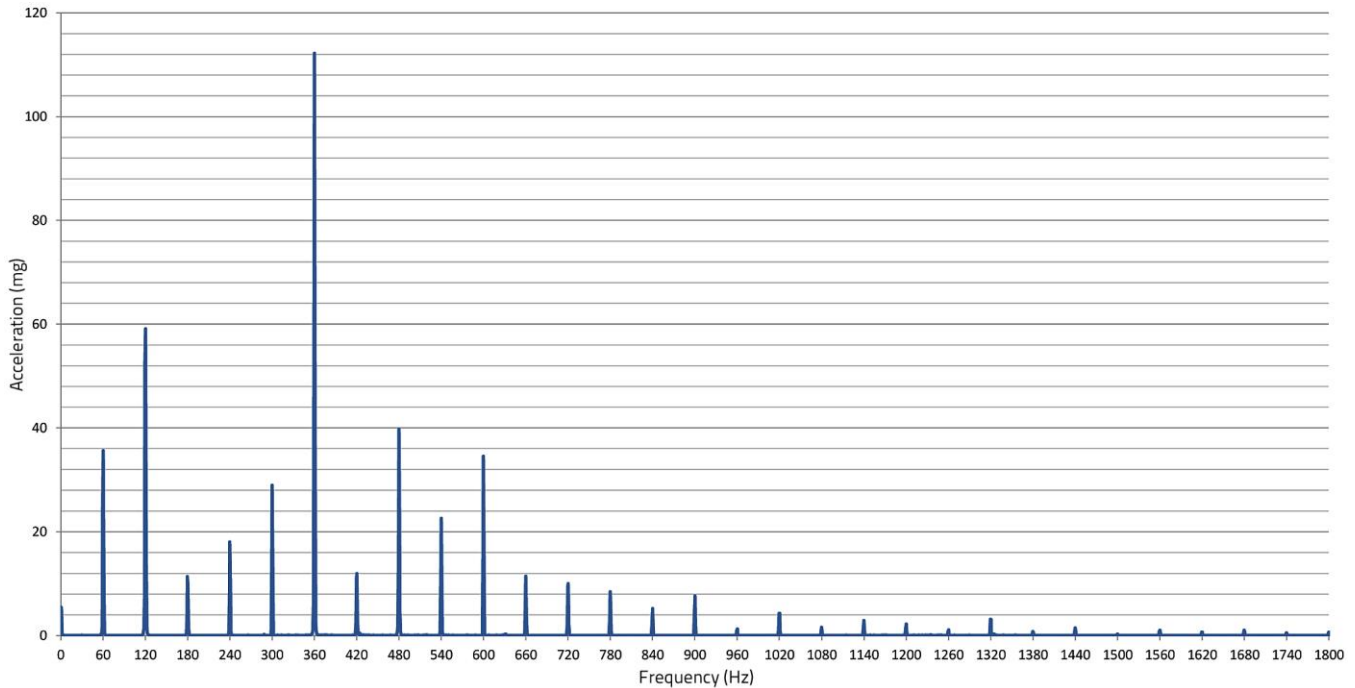

**Figure A-10. Average Peak Acceleration ( $A_z$ ) for the Hard Mount Test**

Figure A-11 shows the average of the peak force ( $F_x$ ) results for four cryocoolers tested in the hard mount configuration. The x-axis of the chart shows the frequency spectrum of the vibrations recorded in the cryocooler's x-axis. The y-axis of the chart show the average peak force recorded in the cryocooler's x-axis at each frequency.

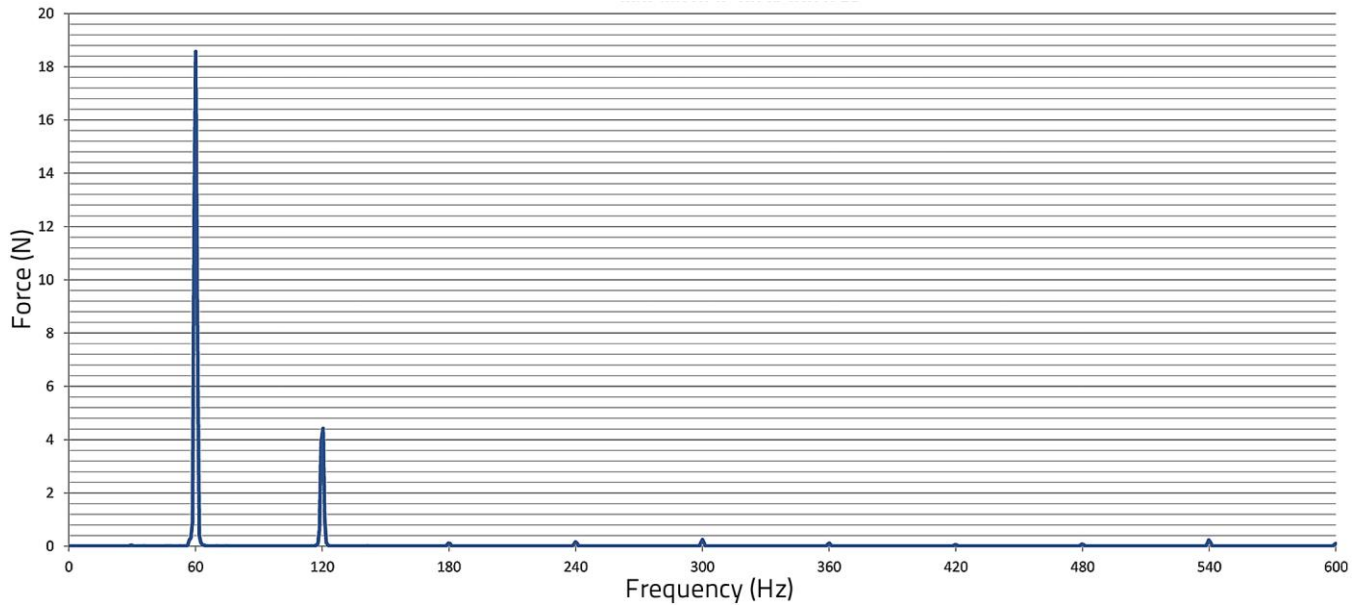

**Figure A-11. Average Peak Force ( $F_x$ ) for the Hard Mount Test**

Figure A-12 shows the average of the peak force ( $F_y$ ) results for four cryocoolers tested in the hard mount configuration. The x-axis of the chart shows the frequency spectrum of the vibrations recorded in the cryocooler's y-axis. The y-axis of the chart show the average peak force recorded in the cryocooler's y-axis at each frequency.

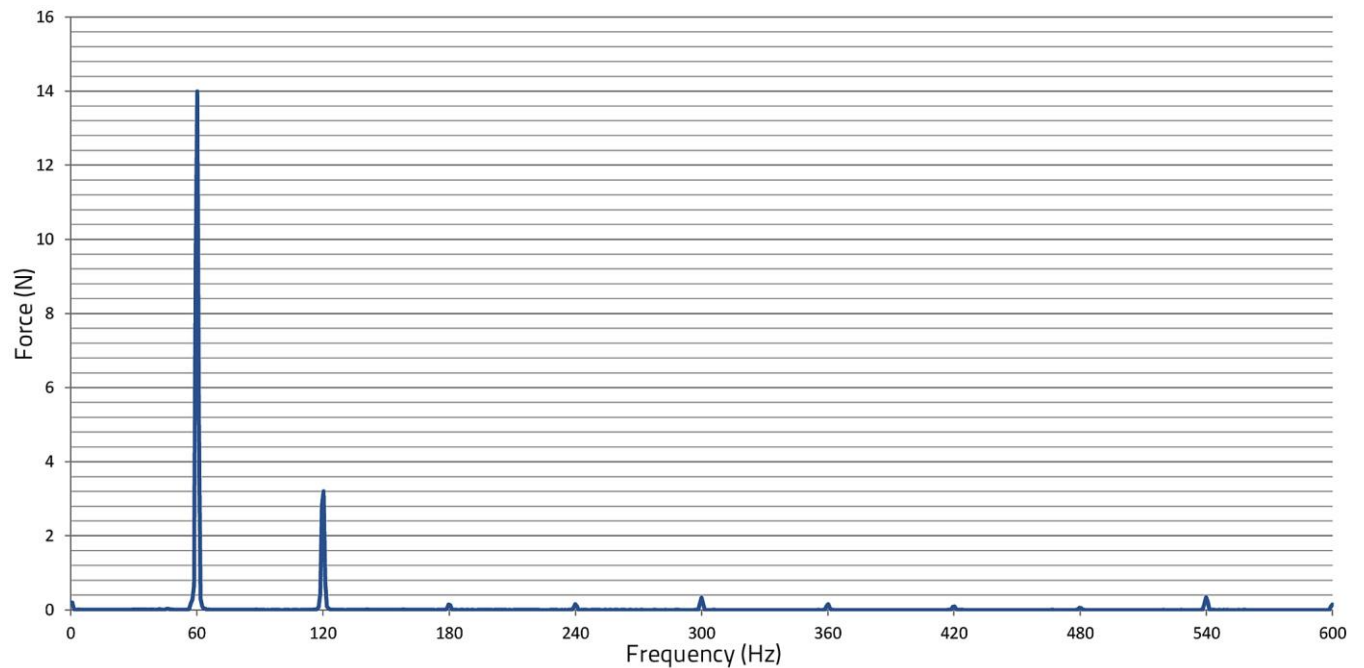

**Figure A-12. Average Peak Force ( $F_y$ ) for the Hard Mount Test**

Figure A-13 shows the average of the peak force (Fz) results for four cryocoolers tested in the hard mount configuration. The x-axis of the chart shows the frequency spectrum of the vibrations recorded in the cryocooler’s z-axis. The y-axis of the chart show the average peak force recorded in the cryocooler’s z-axis at each frequency.

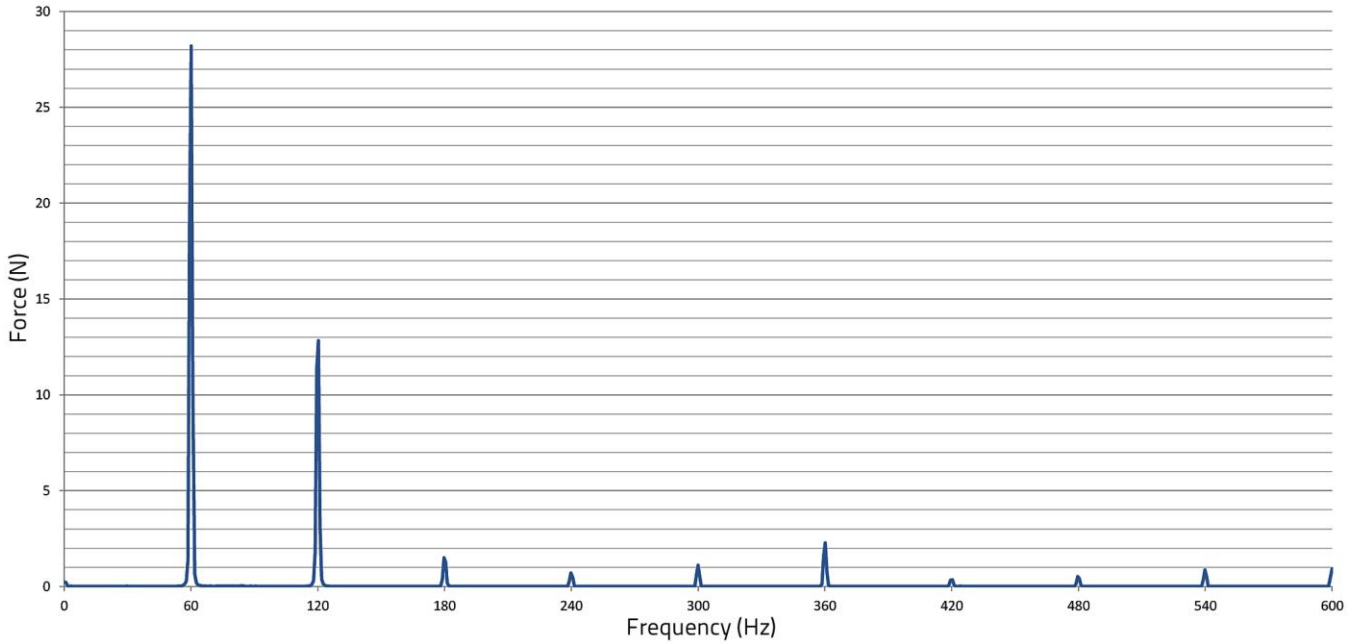

**Figure A-13. Average Peak Force (Fz) for the Hard Mount Test**

### Hard Mount RMS Acceleration & Force

Table A-2 lists the Root Mean Square (RMS) of the acceleration and force results for the hard mount test.

**Table A-2. Hard Mount RMS Acceleration & Force**

Peak Acceleration or Peak Force	RMS Value
Az	9.74 mg
Fx	3.56 N
Fy	1.41 N
Fxy	3.83 N
Fz	8.44 N
Fxyz Vector Magnitude	9.26 N

# Appendix B

## Command Reference

### Conventions

The following conventions are used in this appendix:

- “<CR>” is a symbol used to represent the carriage return character. The controller requires the carriage return character at the end of each command. In the examples in this section, “<CR>” is used to emphasize this requirement and to mean “press the Enter key”. (Pressing the Enter key sends the carriage return character and a line feed character to the terminal emulator program, which only sends the carriage return character to the controller.)
- “<Value>” means “type the value that you want the command to use”.
- “<Password>” means “type the currently-set password”.

### User-Lockable Commands

The commands listed in table B-1 make up the group of commands that you can lock with the **LOCK=<Password>** command. Once these commands are locked, the parameters related to these commands cannot be changed unless you first unlock the entire group of commands using the **UNLOCK=<Password>** command. The default password is **STIRLING**. You can change the password using the **SET PASS=<Value>** command when the commands are unlocked. Use the **LOCK** command to determine if the commands are locked or unlocked. The controller is shipped with these commands in the unlocked state.

**Important** – If you try to change a parameter associated with one of the lockable commands when the commands are locked, the controller will return the current value of the parameter; it will not return a message saying that the parameter is locked.

**Table B-1. User-Lockable Commands for the Generation II Controller (Software Version 2.0.0)**

Short Description	Command
Change Default Control Mode	<b>SAVE PID</b>
Reset Controller Parameters to Factory Defaults	<b>RESET=F</b>
Set Control Mode	<b>SET PID=&lt;Value&gt;</b>
Set Integral Constant of Temp. Control Loop	<b>SET KI=&lt;Value&gt;</b>
Set Proportional Constant of Temp. Control Loop	<b>SET KP=&lt;Value&gt;</b>
Set Soft Stop Control Mode	<b>SET SSTOPM=&lt;Value&gt;</b>
Set Soft-Stop State	<b>SET SSTOP=&lt;Value&gt;</b>
Set Target Power Output	<b>SET PWOUT=&lt;Value&gt;</b>
Set Target Temperature	<b>SET TTARGET=&lt;Value&gt;</b>
Set Temperature Band	<b>SET TBAND=&lt;Value&gt;</b>
Set Thermostat Mode	<b>SET TSTATM=&lt;Value&gt;</b>
Set User-Defined Maximum Power Output	<b>SET MAX=&lt;Value&gt;</b>
Set User-Defined Minimum Power Output	<b>SET MIN=&lt;Value&gt;</b>

## Command Listing

Table B-2 lists all of the valid commands that you can send to the generation II controller. The commands are grouped under the applicable parameter name and the parameter names are in alphabetical order.

**Table B-2. All Commands for the Generation II Controller (Software Version 2.0.0)**

Short Description	Command
<b>Cold Tip Temperature</b> Display Cold-Tip Temperature .....	<b>TC</b>
<b>Control Mode</b> Set Control Mode..... Display Current Control Mode .....	<b>SET PID=&lt;Value&gt;</b> <b>SET PID</b>
Change Default Control Mode .....	<b>SAVE PID</b>
<b>Configured Cryocooler Type</b> Display Configured Cryocooler Type .....	<b>MODE</b>
<b>Controller Code Version</b> Display Controller Code Version.....	<b>VERSION</b>
<b>Controller Serial Number</b> Display Controller Serial Number .....	<b>SERIAL</b>
<b>Controller Parameters</b> Reset Controller Parameters to Factory Defaults .....	<b>RESET=F</b>
<b>Cooler Power as Measured by Controller</b> Display Cooler Power as Measured by Controller .....	<b>P</b>
<b>Current Commanded Power &amp; Power Limits</b> Display Current Commanded Power & Power Limits .....	<b>E</b>
<b>Error Code</b> Display Error Code .....	<b>ERROR</b>
<b>Integral Constant of Temperature Control Loop</b> Set Integral Constant of Temperature Control Loop..... Display Integral Constant of Temperature Control Loop .....	<b>SET KI=&lt;Value&gt;</b> <b>SET KI</b>
<b>Operating State</b> Display Operating State .....	<b>STATE</b>
<b>Proportional Constant of Temperature Control Loop</b> Set Proportional Constant of Temperature Control Loop .....	<b>SET KP=&lt;Value&gt;</b>
Display Proportional Constant of Temperature Control Loop .....	<b>SET KP</b>
<b>Soft-Stop Control Mode</b> Set Soft-Stop Control Mode..... Display Soft-Stop Control Mode .....	<b>SET SSTOPM=&lt;Value&gt;</b> <b>SET SSTOPM</b>

(continues on next page)

**Table B-2. All Commands for the Generation II Controller (Software Version 2.0.0) (continued)**

<b>Soft-Stop State</b>	
Set Soft-Stop State .....	<b>SET SSTOP=&lt;Value&gt;</b>
Display Soft-Stop State .....	<b>SET SSTOP</b>
<b>Target Power Output</b>	
Set Target Power Output .....	<b>SET PWOUT=&lt;Value&gt;</b>
Display Target Power Output .....	<b>SET PWOUT</b>
<b>Target Temperature</b>	
Set Target Temperature .....	<b>SET TTARGET=&lt;Value&gt;</b>
Display Target Temperature .....	<b>SET TTARGET</b>
<b>Temperature Band</b>	
Set Temperature Band .....	<b>SET TBAND=&lt;Value&gt;</b>
Display Temperature Band .....	<b>SET TBAND</b>
<b>Thermostat Mode</b>	
Set Thermostat Mode .....	<b>SET TSTATM=&lt;Value&gt;</b>
Display Thermostat Mode .....	<b>SET TSTATM</b>
<b>Thermostat State</b>	
Display Thermostat State .....	<b>TSTAT</b>
<b>User-Defined Minimum &amp; Maximum Power Output</b>	
Set User-Defined Minimum Power Output .....	<b>SET MIN=&lt;Value&gt;</b>
Display User-Defined Minimum Power Output .....	<b>SET MIN</b>
Set User-Defined Maximum Power Output .....	<b>SET MAX=&lt;Value&gt;</b>
Display User-Defined Maximum Power Output .....	<b>SET MAX</b>
Display User-Defined Minimum & Maximum Power Output .....	<b>SHOW MX</b>
<b>User-Lockable Commands</b>	
Lock User-Lockable Commands .....	<b>LOCK=&lt;Password&gt;</b>
Unlock User-Lockable Commands .....	<b>UNLOCK=&lt;Password&gt;</b>
Set User Password .....	<b>SET PASS=&lt;Value&gt;</b>
Display User Lock State .....	<b>LOCK</b>

## Command Descriptions & Examples

This section contains a description of each command and an example showing how to use each command including the expected results. The first line in an example's computer display box is what is shown on the display as you type, before you press the Enter key. The second and following lines show the information returned from the controller after you press the Enter key.

**Note** – All parameters set using these commands will be retained in memory when the controller is power-cycled unless otherwise noted.

### Cold Tip Temperature

Cold tip temperature is the temperature that the controller calculates based on the resistance it detects across the RTD leads.

#### Display Cold-Tip Temperature

Use the **TC** command to display the current cold tip temperature in kelvins.

**Example:**

You type: **TC**<CR>

The computer displays: 

<b>TC</b> <b>295 . 21</b>
------------------------------

The **295 . 21** returned in this example indicates that the cold tip temperature is 295.21 K.

### Control Mode

The controller operates the CT cryocooler in one of two modes: temperature control mode, or power control mode. The temperature control mode is the factory default operating mode with a factory default target temperature of 77 K.

#### Set Control Mode

Use the **SET PID=<Value>** command to change the control mode that's currently being used.

Entering a value of **0** changes the control mode currently in use to the power control mode. In this mode, the controller will supply power to the cryocooler at the target power level set by the user. (You can use the **SET PWROUT=<Value>** command to change the target power output setting.)

Entering a value of **2** changes the control mode currently in use to the temperature control mode. In this mode, the controller will try to maintain the cold tip at the target temperature setting. (You can use the **SET TTARGET=<Value>** command to change the target temperature setting.)

The control mode will revert to the default control mode upon cycling the power. (You can use the **SAVE PID** command to change the default control mode to the control mode that's currently in use.)

**Example:**

You type: **SET PID=2**<CR>

The computer displays: 

<b>SET PID=2</b> <b>002 . 00</b>
-------------------------------------

The **002 . 00** returned in this example indicates that the controller is in temperature control mode and will attempt to maintain the cold tip at the target temperature setting.

### Display Current Control Mode

Use the **SET PID** command to display the controller control mode that is currently in use.

A return of **000.00** indicates that power control mode is currently in use.

A return of **002.00** indicates that temperature control mode is currently in use.

**Example:**

You type: **PID<CR>**

The computer displays:

```
PID
002.00
```

The **002.00** returned in this example indicates that the temperature control mode is currently in use.

### Change Default Control Mode

Use the **SAVE PID** command to save the control mode that is currently in use as the new default control mode. The factory-set default control mode is temperature control mode. (You can use the **SET PID** command to display the control mode that is currently in use, and you can use the **SET PID=<Value>** command to specify which control mode to use.) The control mode that you save with this command will be the control mode used after the system is power cycled.

A return of **000.00** indicates that power control mode has been saved as the default control mode. A return of **002.00** indicates that temperature control mode has been saved as the default control mode.

**Example:**

You type: **SAVE PID<CR>**

The computer displays:

```
SAVE PID
000.00
```

The **000.00** returned in this example indicates that the power control mode was saved as the default control mode.

## Configured Cryocooler Type

The configured cryocooler type is the type of cryocooler that the controller is configured to work with.

### Display Configured Cryocooler Type

Use the **MODE** command to display the one-digit code that represents the configured cryocooler type according to the list of return codes listed below:

- 000.00** – Sunpower reserved mode
- 001.00** – CryoTel CT
- 002.00** – CryoTel GT
- 003.00** – CryoTel MT

**Example:**

You type: **MODE<CR>**

The computer displays:

```
MODE
001.00
```

The **001.00** returned in this example indicates that the controller is configured to work with a CryoTel CT.

## Controller Code Version

The controller code version is the version number of the software code that is installed in the controller. This is the same software code version number that's printed on the third line of the controller's product label located on the top of the controller.

### *Display Controller Code Version*

Use the **VERSION** command to display the controller code version. (You can also use the **SERIAL** command to display the controller code version number along with other information.)

**Example:**

You type: **VERSION**<CR>

The computer displays: 

<b>VERSION</b> <b>v2.0.0</b>
---------------------------------

The **2.0.0** returned in this example indicates that version 2.0.0 of the controller software is installed in the controller.

## Controller Serial Number

The controller's serial number is printed on the first line of the controller's product label located on the top of the controller.

### *Display Controller Serial Number*

Use the **SERIAL** command to display the controller's serial number in addition to the drawing number and revision level of the controller's circuit board, and the version number of the installed software code. The software code version number is the same software code version number that's returned using the **VERSION** command and is also printed on the third line of the controller's product label.

**Example:**

You type: **SERIAL**<CR>

The computer displays: 

<b>SERIAL</b> <b>300EE-99656-108-001</b> <b>REV4.1 v2.0.0-50032217049</b>
---

The **300EE-99656-108-001 REV4.1** returned in this example is the drawing number and revision level of the controller's circuit board.

**v2.0.0** indicates that version 2.0.0 of the controller software is installed in the controller.

**50032217049** is controller's serial number.

## Controller Parameters

Table B-3 lists the factory defaults for the controller parameters.

**Table B-3. Controller Parameters' Factory Defaults**

Parameter Description	Parameter	Default Value	Meaning of Default Value
Configured Cryocooler Type	<b>MODE</b>	001.00	CryoTel CT
Control Mode	<b>PID</b>	002.00	temperature control mode
Integral Constant of Temp. Control Loop	<b>KI</b>	001.00000	1
Proportional Constant of Temp. Control Loop	<b>KP</b>	050.00000	50
Soft-Stop Mode	<b>SSTOPM</b>	000.00	<b>SET SSTOP=&lt;Value&gt;</b> controls soft-stop state
Soft-Stop State	<b>SSTOP</b>	000.00	soft stop disabled
Target Power Output	<b>PWOUT</b>	000.00	0 W
Target Temperature	<b>TTARGET</b>	077.00	77 K
Temperature Band	<b>TBAND</b>	000.50	±0.5 K
Thermostat Mode	<b>TSTATM</b>	000.00	thermostat function disabled
User-Defined Maximum Power Output	<b>MAX</b>	300.00	300 W
User-Defined Minimum Power Output	<b>MIN</b>	000.00	0 W
User Lock State	<b>LOCK</b>	000.00	unlocked
User Password	<b>PASS</b>	<b>STIRLING</b>	STIRLING

### *Reset Controller Parameters to Factory Defaults*

Use the **RESET=F** command to reset the controller parameters to their factory defaults as listed in table B-3.

**Example:**

You type: **RESET=F<CR>**

The computer displays:

```

RESET=F
RESETTING TO FACTORY DEFAULT...
FACTORY RESET COMPLETE!
    
```

## Cooler Power as Measured by Controller

Cooler power as measured by the controller is how much electrical power in watts the cryocooler is using *as measured by the controller*. (This is not necessarily the same as the power level that the controller is commanding as displayed by the **E** command.)

### Display Cooler Power as Measured by Controller

Use the **P** command to display cooler power as measured by the controller.

**Example:**

You type: **P**<CR>

The computer displays: **P**  
070.00

The **070.00** returned in this example indicates that the cryocooler is consuming 70.00 watts of electrical power as measured by the controller.

**Note** – **P** is measured and **E** (next section) is commanded.

## Current Commanded Power & Power Limits

The current commanded power is current power output that the controller *is commanding* to be supplied to the cryocooler. The current power limits are the minimum and maximum controller power output levels that the controller calculates to be the appropriate limits based on the current conditions in the system.

### Display Current Commanded Power & Power Limits

Use the **E** command to display the current commanded power and the power limits.

The first line of the values returned by this command is the maximum allowable power output to the cryocooler for the current cold tip temperature. This number will be either the maximum safe power output, or the user-defined maximum power output, whichever is lower. (The maximum safe power output to the cryocooler is a function of the cold tip temperature and increases as the cold tip temperature decreases [see figure 2-6]. The maximum safe power output at 77 K is 165 W.)

The second line of the values returned by this command is the minimum allowable power output to the cryocooler. This number will be either the minimum safe power output, or the user-defined minimum power output, whichever is higher. (The minimum safe power output to the cryocooler is a function of the cold tip temperature, but is steady at 60 W over most of the operating range [see figure 2-6]. The minimum safe power output at 77 K is 60 W.)

The third line of the values returned by this command is the current commanded power (not necessarily the target power output set for power control mode or the power the cryocooler is using as displayed by the **P** command). All values are in watts.

**Example:**

You type: **E**<CR>

The computer displays: **E**  
165.00  
060.00  
120.00

The **165.00** returned in this example indicates that the controller has calculated that 165 W is the maximum allowable power output of the controller given the current cold tip temperature.

The **060.00** returned in this example indicates that the controller has calculated that 60 W is the minimum allowable power output of the controller given the current cold tip temperature.

The **120.00** returned in this example indicates that the controller is currently commanding a controller power output level of 120 W.

## Error Code

An error code is a six-digit binary number that identifies which, if any, errors are occurring. The position of the 1 within the error code determines what error is being reported (table B-4). Multiple errors are indicated by multiple 1s in the error code, each 1 representing a different error. An error code consisting of six zeros means there are no errors.

**Table B-4. Error Codes**

Error Code	Name of the Error Indicated
000001	Over Current
000010	Jumper Error
000100	Serial Communication Error
001000	Non-Volatile Memory Error
010000	Watchdog Error
100000	Temperature Sensor Error

### Display Error Code

Use the **ERROR** command to display the error code as defined in table B-4.

**Example:**

You type: **ERROR<CR>**

The computer displays: **ERROR  
101000**

The **101000** error code returned in this example indicates that two errors are occurring: the temperature sensor error (the 1 in the first place from the left), and the non-volatile memory error (the 1 in the third place from the left).

## Integral Constant of Temperature Control Loop

In some applications, advanced users experienced in tuning PID control loops may want to modify the PI constants to tune the temperature control loop to better match the dynamics of their individual system. The default integral constant for the CT cryocooler is 1.0.

### Set Integral Constant of Temperature Control Loop

Use the **SET KI=<Value>** command to set the integral constant of the temperature control loop.

**Example:**

You type: **SET KI=0.6<CR>**

The computer displays: **SET KI=0.6  
000.60000**

The **000.60000** returned in this example indicates that the integral constant of the temperature control loop is 0.6.

**Display Integral Constant of Temperature Control Loop**

Use the **SET KI** command to display the integral constant of the temperature control loop.

**Example:**

You type: **SET KI<CR>**

The computer displays: **SET KI  
000.10000**

The **000.10000** returned in this example is the integral constant of the temperature control loop.

**Operating State**

The operating state of the controller is defined as the current value of the controller's operating parameters which are listed and described in table B-5. The factory default values for these parameters (except TSTAT) are listed in table B-3.

**Table B-5. Controller's Operating Parameters**

Operating Parameter Name	Operating Parameter Description
MODE	Cryocooler Model Designation
TSTATM	Thermostat Mode
TSTAT	Thermostat State
SSTOPM	Soft-Stop Control Mode
SSTOP	Soft-Stop State
PID	Control Mode Currently in Use
LOCK	User Lock State
MAX	User-Defined Maximum Power Output
MIN	User-Defined Minimum Power Output
PWOUT	Target Power Output
TTARGET	Target Temperature
TBAND	Temperature Band
TEMP KP	Proportional Constant of Temperature Control Loop
TEMP KI	Integral Constant of Temperature Control Loop

### Display Operating State

Use the **STATE** command to display a list of the controller's operating parameters (as described in table B-5) and their current values. All of the individual parameter values can also be displayed using the corresponding individual parameter display commands listed elsewhere in this appendix. This command is useful when troubleshooting the system.

**Example:**

You type: **STATE**<CR>

The computer displays:

```
STATE
MODE      = 001.00
TSTATM    = 000.00
TSTAT     = 000.00
SSTOPM    = 000.00
SSTOP     = 000.00
PID       = 002.00
LOCK      = 000.00
MAX       = 300.00
MIN       = 000.00
PWOUT     = 000.00
TTARGET   = 077.00
TBAND     = 000.50
TEMP KP   = 048.00000
TEMP KI   = 000.59999
```

See the corresponding Display and Set command sections in this appendix for explanations of the displayed parameter values.

### Proportional Constant of Temperature Control Loop

In some applications, advanced users experienced in tuning PID control loops may want to modify the PI constants to tune the temperature control loop to better match the dynamics of their individual system. The default proportional constant for the CT cryocooler is 50.0.

#### Set Proportional Constant of Temperature Control Loop

Use the **SET KP=<Value>** command to set the proportional constant of the temperature control loop.

**Example:**

You type: **SET KP=48.0**<CR>

The computer displays:

```
SET KP=48.0
048.00000
```

The **048.00000** returned in this example indicates that the proportional constant of the temperature control loop is 48.0.

#### Display Proportional Constant of Temperature Control Loop

Use the **SET KP** command to display the proportional constant of the temperature control loop.

**Example:**

You type: **SET KP**<CR>

The computer displays:

```
SET KP
040.00000
```

The **040.00000** returned in this example indicates that the proportional constant of the temperature control loop is 40.0.

## Soft-Stop Control Mode

The soft-stop control mode identifies the method that has been selected to enable and disable the soft-stop function. There are two methods: one is to use the **SET SSTOP=<Value>** command; the other is to use Digital Input 1 (pin 5 on the controller's I/O connector). In the Digital Input 1 method, setting the input high enables the soft-stop function. The Onboard Isolated 5 V output on pin 10 or 12 on the controller's I/O connector can be used to set the input high. Setting the input low or disconnecting it disables the soft-stop function.

### Set Soft-Stop Control Mode

Use the **SET SSTOPM=<Value>** command to set the soft-stop control mode, i.e., to select the method that will be used to enable and disable the soft-stop function.

Entering a value of **0** (mode 0) allows the soft-stop function to be enabled or disabled using only the **SET SSTOP=<Value>** command.

Entering a value of **1** (mode 1) allows the soft-stop function to be enabled or disabled using only Digital Input 1.

#### Example:

You type: **SET SSTOPM=1<CR>**

The computer displays: **SET SSTOPM=1  
001.00**

The **001.00** returned in this example indicates that Digital Input 1 is being used to enable or disable the soft-stop function.

### Display Soft-Stop Control Mode

Use the **SET SSTOPM** command to display the current soft-stop control mode of the controller, i.e., which of the two methods of controlling the soft-stop function has been chosen.

A return of **000.00** (mode 0) indicates that only the **SET SSTOP=<Value>** command can be used to enable or disable the soft-stop function.

A return of **001.00** (mode 1) indicates that only Digital Input 1 (pin 5 on the controller's I/O connector) can be used to enable or disable the soft-stop function.

#### Example:

You type: **SET SSTOPM<CR>**

The computer displays: **SET SSTOPM  
001.00**

The **001.00** returned in this example indicates that only Digital Input 1 can be used to enable or disable the soft-stop function.

## Soft-Stop State

The soft-stop state indicates whether the soft-stop function is enabled or disabled. With the soft-stop function enabled, the cryocooler is stopped, or is being ramped down, parked, and stopped, and will not start up when power is cycled to the controller. With the soft-stop function disabled, the cryocooler is in the process of starting up or is running, and will start up normally when power to the controller is cycled.

### Set Soft-Stop State

Use the **SET SSTOP=<Value>** command to begin a soft stop of the cryocooler, or to start the cryocooler from its stopped state. A soft stop is the recommended shutdown method in which the controller slowly ramps down operation of the cryocooler and parks the piston against the end stop before shutting it down completely. This reduces vibration, allows the controller to remain on, and reduces the risk of self-excitation (when turning off the cryocooler at very low temperatures—below 77 K). This command will only work if the soft-stop control mode is set to mode 0. (If set to mode 1, then Digital Input 1 is used to control the soft-stop state.)

Entering a value of **0** restarts a stopped cryocooler and disables the soft-stop function.

Entering a value of **1** begins a soft stop of the cryocooler and enables the soft-stop function. Do not remove power from the controller until the shutdown process has been completed and the word **COMPLETE** is displayed on the computer screen.

#### Example 1 of 2:

You type: **SET SSTOP=0<CR>**

The computer displays: **SET SSTOP=0  
000.00**

The **000.00** returned in this example indicates that the controller's soft-stop function is disabled. If the cryocooler was not running when the command was sent, the cryocooler will start to run. With the soft-stop function now disabled, the next time power to the controller is cycled, the cryocooler will start up normally.

#### Example 2 of 2:

You type: **SET SSTOP=1<CR>**

The computer displays: **SET SSTOP=1  
001.00  
SHUTTING DOWN  
...  
COMPLETE**

The **001.00** returned in this example indicates that the controller's soft-stop function is enabled. The words **SHUTTING DOWN** and the animated three-dot progress bar mean that the cryocooler is in the process of slowly ramping down, parking the piston against the end stop, and stopping. Once completed (the cryocooler stopped), the word **COMPLETE** replaces the three-dot progress bar. With the soft-stop function now enabled, the cryocooler will not start up when power is cycled to the controller.

### Display Soft-Stop State

Use the **SET SSTOP** command to display the current soft-stop state, i.e., whether the soft-stop function is enabled or disabled.

A return of **000.00** indicates that the soft-stop function is disabled.

A return of **001.00** indicates that soft-stop function is enabled.

**Example:**

You type: **SET SSTOP<CR>**

The computer displays: **SET SSTOP  
000.00**

The **000.00** returned in this example indicates that the soft-stop function is disabled, meaning that the cryocooler will start up normally when power to the controller is cycled.

## Target Power Output

The target power output setting is the power level that the user has set as the target power output to send to the cryocooler when in power control mode. This setting is only a *target* power level: the actual power output that the controller is commanding is displayed by the **E** command and is subject to the power limits also displayed by the **E** command. The default target power output setting is 0 W.

While any number from 0.0 to 999.99 can be entered as the target power output, the controller will not command a power level that is outside of the currently-calculated allowable operating power range of the cryocooler (as shown using the **E** command) regardless of the target power output set by the user. Refer to the **E** command section for details on how the allowable operating power range is calculated.

### Set Target Power Output

Use the **SET PWOUT=<Value>** command to change the target power output setting.

**Example:**

You type: **SET PWOUT=100<CR>**

The computer displays: **SET PWOUT=100  
100.00**

The **100.00** returned in this example indicates that the target power output setting is 100 W. If the controller is in power control mode and 100 W is within the power limits displayed by the **E** command, then the controller will adjust its operating parameters as needed to attain a power output of 100 W.

### Display Target Power Output

Use the **SET PWOUT** command to display the target power output setting.

**Example:**

You type: **SET PWOUT<CR>**

The computer displays: **SET PWOUT  
095.00**

The **095.00** returned in this example indicates that the target power output setting is 95 W.

## Target Temperature

The target temperature is the target cold tip temperature that the controller will try to attain,  $\pm 0.1$  K, when the controller is in temperature control mode. The default target temperature is 77 K.

### Set Target Temperature

Use the **SET TTARGET=<Value>** command to set the target temperature.

**Example:**

You type: **SET TTARGET=86<CR>**

The computer displays: **SET TTARGET=86  
086.00**

The **086.00** returned in this example indicates that the target temperature setting is 86 K. If the controller is in temperature control mode, then the controller will adjust the power to the cryocooler as needed to try to attain a cold tip temperature of 86 K  $\pm 0.1$  K.

### Display Target Temperature

Use the **SET TTARGET** command to display the target temperature.

**Example:**

You type: **SET TTARGET<CR>**

The computer displays: **SET TTARGET  
077.00**

The **077.00** returned in this example indicates that the target temperature setting is 77 K.

## Temperature Band

The temperature band is the  $\pm$  tolerance band used with the target temperature to determine when the cold tip is considered to be at the target temperature (for the sole purposes of operating the controller's LEDs and the Digital Out 4 pin on the controller's I/O connector). For example, if the target temperature is set at 77 K, and the  $\pm$  temperature band is set at  $\pm 0.5$  K, and the controller is in temperature control mode, then the green LED will be on and the Digital Out 4 pin will be high (5 V) when the cold tip temperature is 77 K  $\pm 0.5$  K. Also, the red LED will be on and the Digital Out 4 pin will be low (0 V) when the cold tip temperature is outside of that range. The default  $\pm$  temperature band is  $\pm 0.5$  K.

### Set Temperature Band

Use the **SET TBAND=<Value>** command to set the  $\pm$  temperature band in kelvins.

**Example:**

You type: **SET TBAND=1.5<CR>**

The computer displays: **SET TBAND=1.5  
001.50**

The **001.50** returned in this example indicates that the  $\pm$  temperature band is now  $\pm 1.5$  K.

### Display Temperature Band

Use the **SET TBAND** command to display the  $\pm$  temperature band in kelvins.

**Example:**

You type: **SET TBAND<CR>**

The computer displays: **SET TBAND  
000.50**

The **000.50** returned in this example indicates that the set  $\pm$  temperature band is  $\pm 0.5$  K.

### Thermostat Mode

The thermostat mode indicates whether the controller is set to work with a thermostat (mode 1), or is set to not work with a thermostat (mode 0). When in mode 1, a thermostat connected across pin 7 (Digital Input 3) and pin 10 or 12 (Onboard Isolated 5 V Output) of the controller's I/O connector can be used to shut down the cryocooler when the temperature is outside of a desired temperature range. (As long as pin 7 is high [thermostat closed], a running cryocooler is allowed to continue running, but anytime the thermostat becomes open, the controller shuts down the cryocooler. At that point, the thermostat must be closed before the cryocooler can be started up again. This does not generate an error and does not require a power cycle to restart.)

### Set Thermostat Mode

Use the **SET TSTATM=<Value>** command to set the thermostat mode of the controller.

Entering a value of **0** (mode 0) disables the controller's ability to work with a thermostat.

Entering a value of **1** (mode 1) enables the controller's ability to work with a thermostat.

**Example:**

You type: **SET TSTATM=1<CR>**

The computer displays: **SET TSTATM=1  
001.00**

The **001.00** returned in this example indicates that the controller's thermostat function has been enabled.

### Display Thermostat Mode

Use the **SET TSTATM** command to display the current thermostat mode of the controller.

A return of **000.00** indicates that use of a thermostat is disabled.

A return of **001.00** indicates that use of a thermostat is enabled.

**Example:**

You type: **SET TSTATM<CR>**

The computer displays: **SET TSTATM  
001.00**

The **001.00** returned in this example indicates that the ability of the controller to use a thermostat has been enabled.

## Thermostat State

The thermostat state indicates the current state (open or closed) of a thermostat connected across pin 7 and pin 10 or 12 of the controller's I/O connector. This state is only meaningful if thermostat mode has been enabled (using the **SET TSTATM=1** command) and a thermostat is installed.

If the thermostat state is open, that means the cryocooler has been automatically shut down or is in the process of automatically shutting down. The thermostat must then be closed before the cryocooler can be started up again. Startup will happen automatically when the thermostat closes.

### Display Thermostat State

Use the **TSTAT** command to display the current state of the thermostat.

A return of **000.00** indicates that the thermostat is open.

A return of **001.00** indicates that the thermostat is closed.

#### Example:

You type: **TSTAT<CR>**

The computer displays: **TSTAT  
001.00**

The **001.00** returned in this example indicates that the thermostat is closed, allowing the cryocooler to run.

## User-Defined Minimum & Maximum Power Output

The user-defined minimum power output setting for the controller is used in both the power control mode and the temperature control mode. Entering a value that is less than the minimum safe power output to the cryocooler (60 W at 77 K) will not result in damage to the cryocooler because the controller will not command a power that is less than the minimum safe power output to the cryocooler. The minimum power output to the cryocooler will either be the minimum safe power output, or the user-defined minimum power output, whichever is higher. The default user-defined minimum power output setting is 0 W.

The user-defined maximum power output setting for the controller is used in both the power control mode and the temperature control mode. Entering a value that exceeds the maximum safe power output to the cryocooler will not result in damage to the cryocooler because the controller will not command a power that exceeds the maximum safe power output to the cryocooler. The maximum safe power output to the cryocooler is a function of the cold tip temperature and increases as the cold tip temperature decreases. (It's 165 W at 77 K.) The maximum power output to the cryocooler will be either the maximum safe power output, or the user-defined maximum power output, whichever is lower. The default user-defined maximum power output setting is 300 W.

### Set User-Defined Minimum Power Output

Use the **SET MIN=<Value>** command to set the user-defined minimum power output setting for the controller.

#### Example:

You type: **SET MIN=080<CR>**

The computer displays: **SET MIN=080  
080.00**

The **080.00** returned in this example indicates that the user-defined minimum power output setting for the controller is 80 W.

### Display User-Defined Minimum Power Output

Use the **SET MIN** command to display the user-defined minimum power output setting for the controller.

**Example:**

You type: **SET MIN<CR>**

The computer displays: **SET MIN  
080.00**

The **080.00** returned in this example indicates that the user-defined minimum power output setting for the controller is 80 W.

### Set User-Defined Maximum Power Output

Use the **SET MAX=<Value>** command to set the user-defined maximum power output setting for the controller.

**Example:**

You type: **SET MAX=150<CR>**

The computer displays: **SET MAX=150  
150.00**

The **150.00** returned in this example indicates that the user-defined maximum power output setting for the controller is 150 W.

### Display User-Defined Maximum Power Output

Use the **SET MAX** command to display the user-defined maximum power output setting for the controller.

**Example:**

You type: **SET MAX<CR>**

The computer displays: **SET MAX  
150.00**

The **150.00** returned in this example indicates that the user-defined maximum power output setting for the controller is 150 W.

### Display User-Defined Minimum & Maximum Power Output

Use the **SHOW MX** command to display the user-defined minimum and maximum power output settings for the controller. (You can also use the **SET MIN** and **SET MAX** commands to display the same settings individually.)

The first line of the values returned by this command is the used-defined minimum power output setting for the controller. The second line of the values returned by this command is the used-defined maximum power output setting for the controller. All values are in watts.

**Example:**

You type: **SHOW MX<CR>**

The computer displays: **SHOW MX  
080.00  
150.00**

The **080.00** returned in this example indicates that the user-defined minimum power output setting for the controller is 80 W.

The **150.00** returned in this example indicates that the user-defined maximum power output setting for the controller is 150 W.

## User-Lockable Commands

Commands in the user-lockable commands group (table B-1) can be locked so that the parameters associated with those commands cannot be changed. To lock the commands, you must enter a user password. In order to unlock a command, you must unlock the entire group of commands by entering the user password. The default user password is **STIRLING**, but you can change the user password when the commands are unlocked. The controller is shipped with these commands in the unlocked state. If the commands are locked and the user password has been misplaced, the controller must be sent back to Sunpower so that we can unlock the commands.

### Lock User-Lockable Commands

Use the **LOCK=<Password>** command to lock access to the commands in the user-lockable commands group (table B-1). “<Password>” means “type the currently-set password”.

**Example:**

You type: **LOCK=STIRLING<CR>**

The computer displays: **LOCK=STIRLING  
001.00**

The **001.00** returned in this example confirms that the group of lockable commands listed in table B-1 is locked and that the parameters associated with those commands cannot be changed.

**Important** – If you try to change a parameter associated with one of the user-lockable commands when the commands are locked, the controller will return the current value of the parameter; it will not return a message saying that the parameter is locked.

### Unlock User-Lockable Commands

Use the **UNLOCK=<Password>** command to unlock access to the commands in the user-lockable commands group (table B-1). “<Password>” means “type the currently-set password”.

A return of **000.00** confirms that the commands are unlocked.

**Example:**

You type: **UNLOCK=STIRLING<CR>**

The computer displays: **UNLOCK=STIRLING  
000.00**

The **000.00** returned in this example confirms that the commands are unlocked.

### Set User Password

Use the **SET PASS=<Value>** command to define a user password.

Enter an alphanumeric value between 1 and 10 characters in length. This value will replace the previous password.

A return of **001.00** confirms that the password was successfully changed.

**Example:**

You type: **SET PASS=ABC123<CR>**

The computer displays: **SET PASS=ABC123  
001.00**

The **001.00** returned in this example indicates that the controller has changed the password to ABC123.

### *Display User Lock State*

Use the **LOCK** command to display the user lock state.

A return of **000 . 00** indicates that the commands are unlocked.

A return of **001 . 00** indicates that the commands are locked.

**Example:**

You type: **LOCK<CR>**

The computer displays:

<b>LOCK</b> <b>000 . 00</b>
--------------------------------

The **000 . 00** returned in this example indicates that the group of lockable commands listed in table B-1 is unlocked and that the parameters associated with those commands can be changed.

# Appendix C

## Warranty Information

### CryoTel Product Limited Warranty

Sunpower warrants to the original purchaser that this CryoTel® product including the cryocooler and the controller (Product) will be free from defects in material and/or workmanship. This warranty is limited to twenty-four (24) months from date of delivery.

### Limitations & Exclusions

The Buyer's sole and exclusive remedy for breach of the CryoTel Product Limited Warranty is replacement or repair at the discretion of Sunpower and subject to a finding by Sunpower that the unit is defective. The Product that is to be replaced or repaired shall be returned to Sunpower's manufacturing facility at the Buyer's expense.

All repairs and/or replacements shall be performed at Sunpower's manufacturing facility. All units submitted for repair or replacement will be subject to examination by Sunpower's manufacturing personnel in order to verify that the unit is defective. CryoTel units which are determined by Sunpower's manufacturing personnel to have been subjected to misuse, neglect, improper operation or handling, use or care in violation of Sunpower's Use and Care Guidelines (located in the product's Installation & Operation Manual) are not covered by this limited warranty.

This limited warranty shall be void on CryoTel units that have been modified without permission from Sunpower.

THE LIMITED WARRANTY SET FORTH ABOVE IS EXCLUSIVE AND IN LIEU OF ALL OTHER WARRANTIES. SUNPOWER MAKES NO OTHER WARRANTIES, EXPRESS OR IMPLIED, AND SUNPOWER EXPRESSLY DISCLAIMS ALL OTHER WARRANTIES, INCLUDING BUT NOT LIMITED TO IMPLIED WARRANTIES OF MERCHANTABILITY AND FITNESS FOR A PARTICULAR PURPOSE. MOREOVER, THE PROVISIONS SET FORTH ABOVE STATE SUNPOWER'S ENTIRE RESPONSIBILITY AND THE BUYER'S SOLE AND EXCLUSIVE REMEDY WITH RESPECT TO ANY BREACH OF WARRANTY.







Sunpower, Inc.  
2005 E. State St., Suite 104  
Athens, OH 45701 USA  
(740)594-2221  
[www.sunpowerinc.com](http://www.sunpowerinc.com)

710MNL-01000-001 (Rev. 11, 9/06/2018)

**Installation & Operation Manual for the  
CryoTel® CT  
Cryocooler & Gen II Controller**