

Connectors and filters

Voltage regulators and amplifiers

Top	
System: DAMIC-M Frontend Board (based on ADA4817)	
Board: FE_ADA4817	
Created: 14-NOV-2022, Daniel Florin	Revision: 1.00
Modified: 14-DEC-2022, Daniel Florin	Sheet: 1 of 3
Physik Institut Universitaet Zuerich Winterthurerstrasse 190 8057 Zuerich	

TO SAMTEC CABLE

CON200
ERF8-030-01-L-D-RA-L-TR
Female

GND	01	01	02	GND	
VSUP_N	03	03	04	AOUT_0P	
VDD2_CCD	05	06	06	AOUT_0N	
VDD1_CCD	07	05	08	AOUT_1P	
VDRAIN2_CCD	09	08	10	AOUT_1N	
VDRAIN1_CCD	11	11	12	AOUT_2P	
VR2_CCD	13	13	14	AOUT_2N	
VR1_CCD	15	14	16	AOUT_3P	
VSUP_P	17	15	16	AOUT_3N	
GND	19	17	18	GND	
GND	21	19	20	GND	
TG_2	23	21	22	GND	
V3_2	25	23	24	TG_1	
V2_2	27	25	26	26	V3_1
V1_2	29	27	28	28	V2_1
GND	31	29	30	30	V1_1
GND	33	31	32	32	GND
GND	33	31	32	34	GND
H3_L	35	33	34	36	H3_U
H2_L	37	35	36	38	H2_U
H1_L	39	37	38	40	H1_U
DG_2	41	39	40	42	DG_1
RG_2	43	41	42	44	RG_1
GND	45	43	44	46	GND
SW_2	47	45	46	48	SW_1
OG_2	49	47	48	50	OG_1
CLAMPN	51	49	50	52	RESETP
CLAMPP	53	51	52	54	RESETP
GAIN_1	55	53	54	56	GND
GAIN_0	57	55	56	58	GND
GND	59	57	58	60	VSUB_CCD
		59	60		

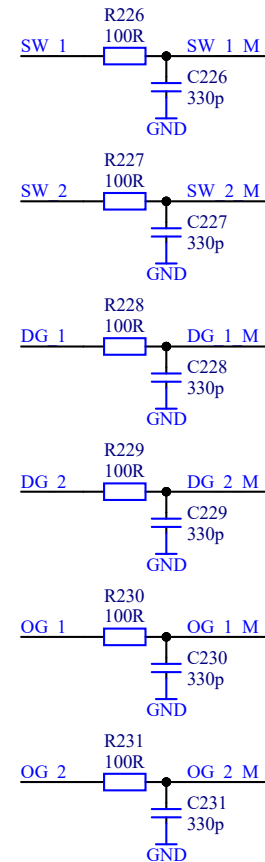
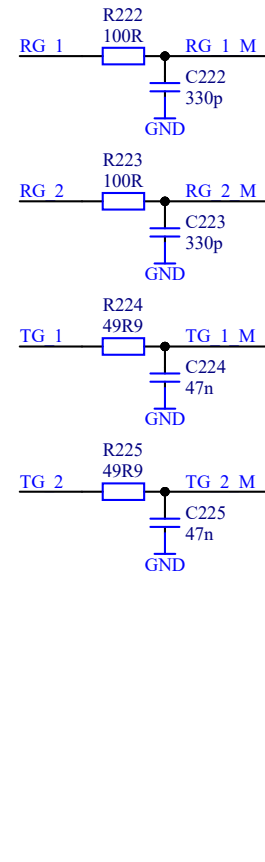
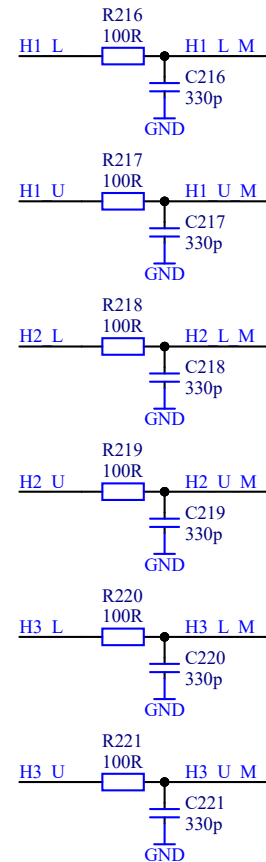
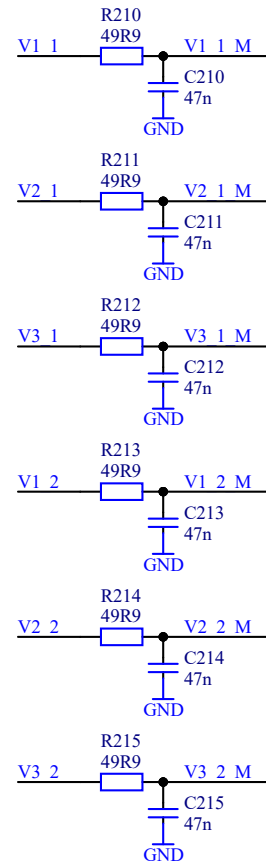

TO VACUUM

CON240
ERM8-030-01-L-D-RA-L-TR
Male

GND	01	01	02	GND	
GND	03	03	04	AIN_0	
VDD2_CCD	05	06	06	GND	
VDD1_CCD	07	05	08	AIN_1	
VDRAIN2_CCD	09	08	10	GND	
VDRAIN1_CCD	11	11	12	AIN_2	
VR2_CCD	13	13	14	GND	
VR1_CCD	15	14	16	AIN_3	
GND	17	15	16	GND	
GND	19	17	18	GND	
GND	21	19	20	GND	
TG_2_M	23	21	22	TG_1_M	
V3_2_M	25	23	24	26	V3_1_M
V2_2_M	27	25	26	28	V2_1_M
V1_2_M	29	27	28	30	V1_1_M
GND	31	29	30	32	GND
GND	33	31	32	34	GND
H3_L_M	35	33	34	36	H3_U_M
H2_L_M	37	35	36	38	H2_U_M
H1_L_M	39	37	38	40	H1_U_M
DG_2_M	41	39	40	42	DG_1_M
RG_2_M	43	41	42	44	RG_1_M
GND	45	43	44	46	GND
SW_2_M	47	45	46	48	SW_1_M
OG_2_M	49	47	48	50	OG_1_M
GND	51	49	50	52	GND
N+	53	51	52	54	GND
N+	55	53	54	56	GND
GND	57	55	56	58	GND
GND	59	57	58	60	VSUB_CCD
		59	60		

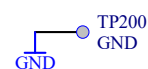
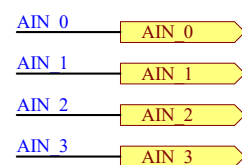
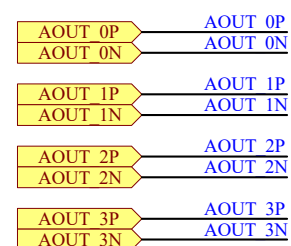
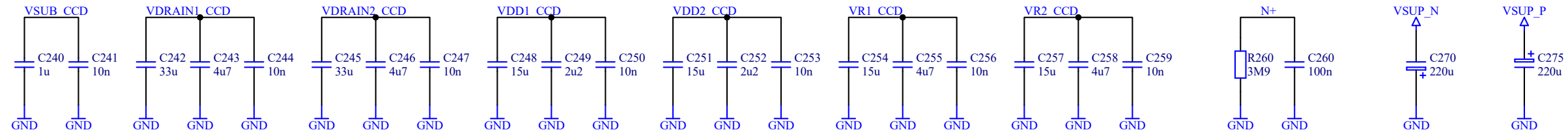

- FID200
- FID201
- FID202

- MH200 M3
- MH201 M3
- MH202 M3
- MH203 M3

Connectors and Filters

System: DAMIC-M Frontend Board (based on ADA4817)	
Board: FE_ADA4817	
Created: 14-NOV-2022, Daniel Florin	Revision: 1.00
Modified: 14-DEC-2022, Daniel Florin	Sheet: 2 of 3
Physik Institut Universitaet Zuerich Winterthurerstrasse 190 8057 Zuerich	

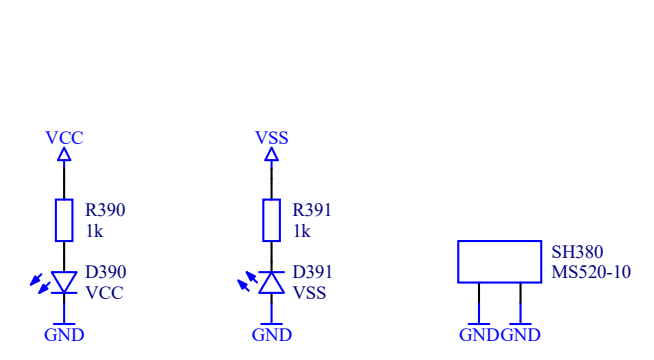
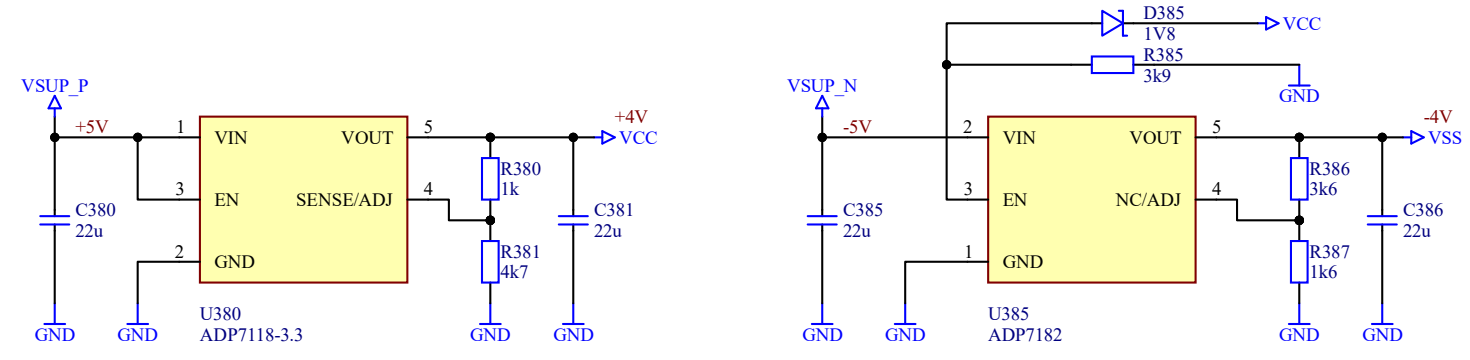
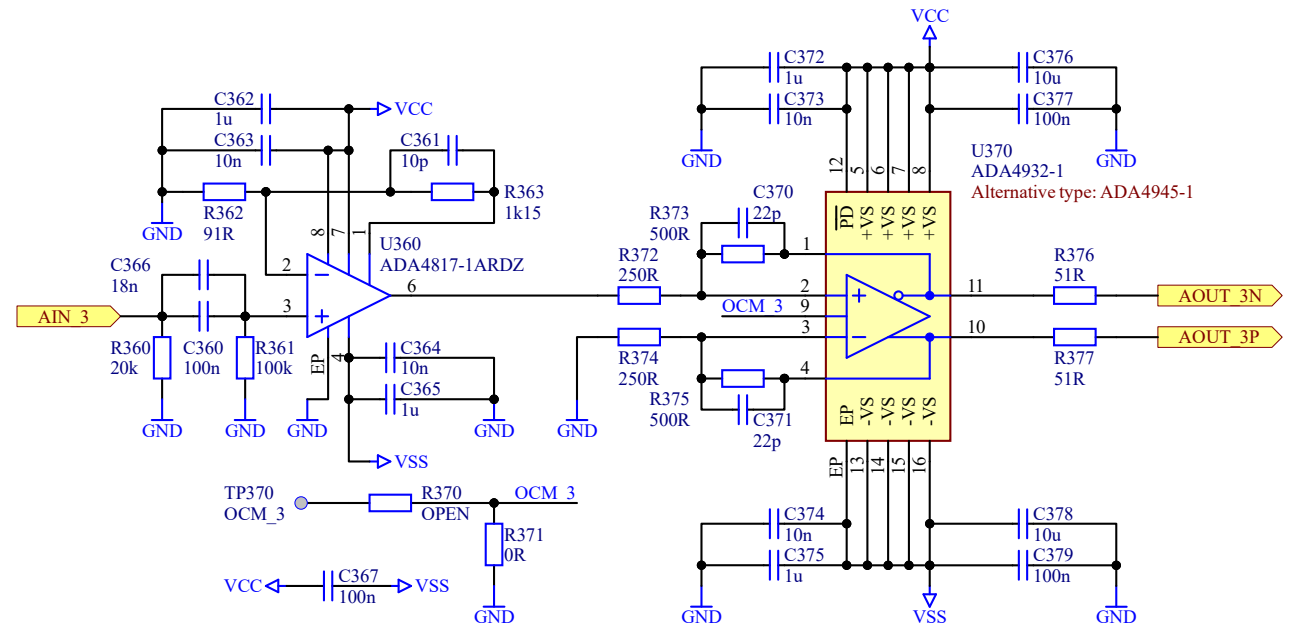
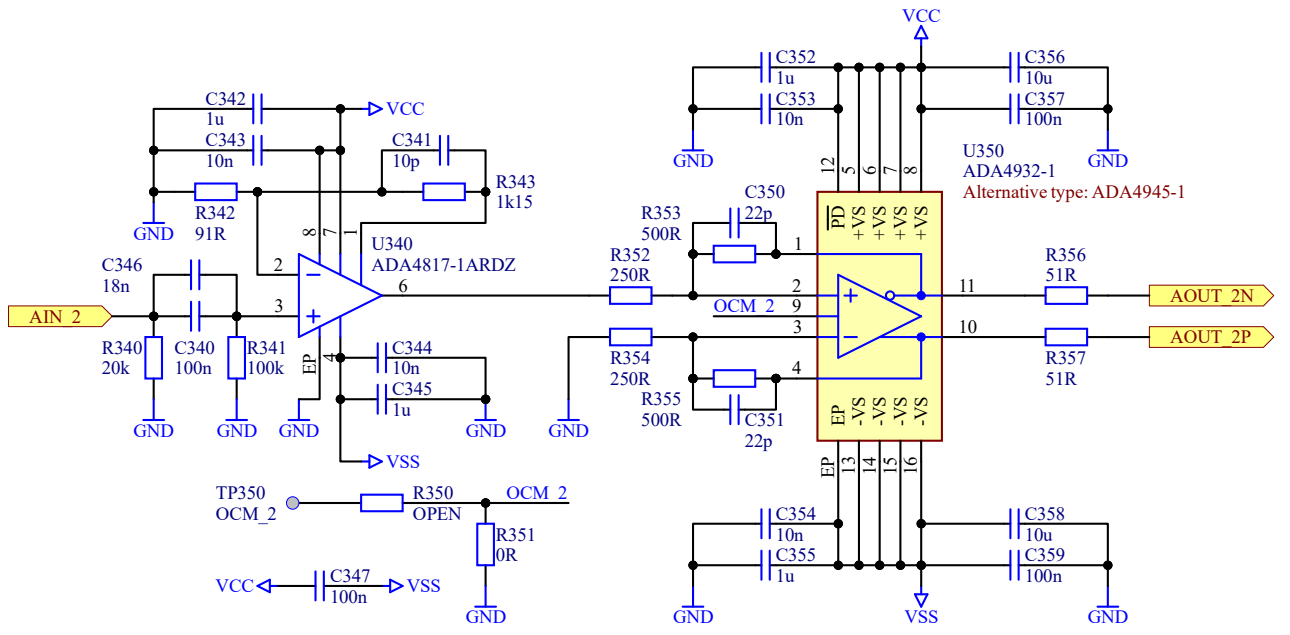
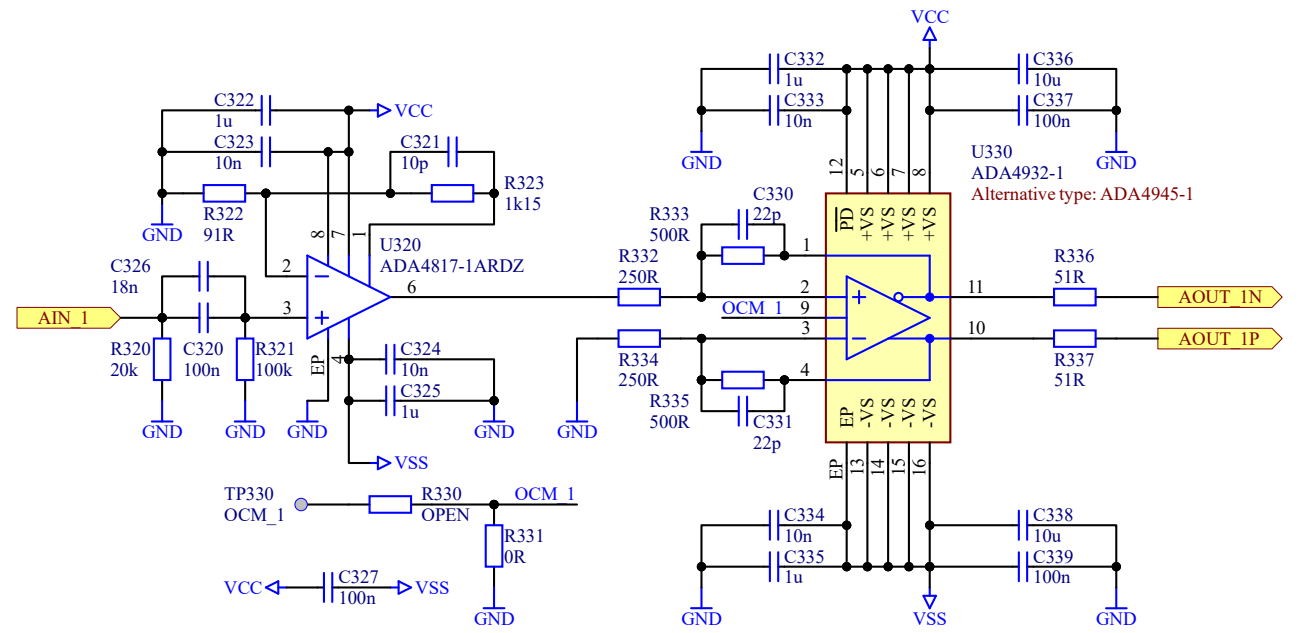
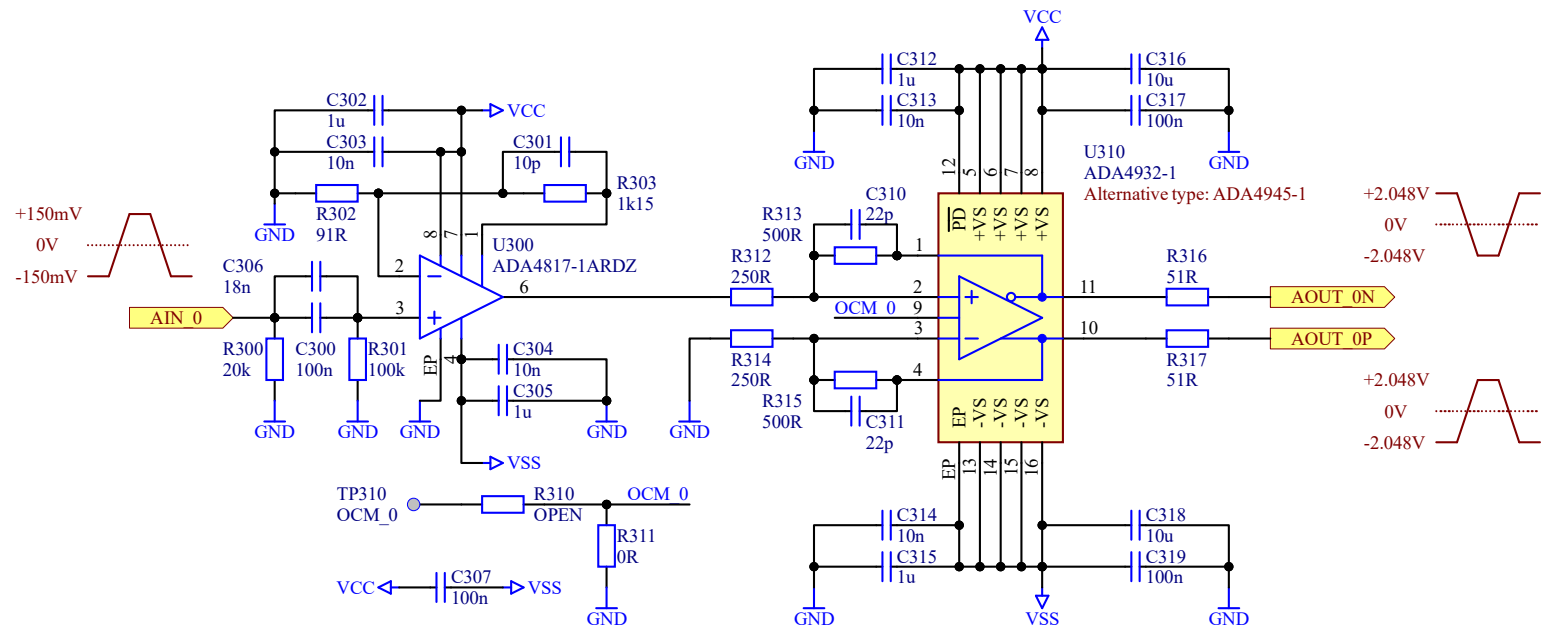

Supply current: 32mA + I_LOAD per channel

Voltage Regulators and Amplifiers	
System: DAMIC-M Frontend Board (based on ADA4817)	
Board: FE_ADA4817	
Created: 14-NOV-2022, Daniel Florin	Revision: 1.00
Modified: 14-DEC-2022, Daniel Florin	Sheet: 3 of 3
Physik Institut Universitaet Zuerich Winterthurerstrasse 190 8057 Zuerich	