

Modified for: $-2V < V_{in} < +2V$
 $S4x_{17} = S4x_{28} = 1K$
 $S4x_{14} = S4x_{31} = 2K$
 $S4x_{21} = S4x_{25} = 470 \text{ Ohm}$
 01/05/2023

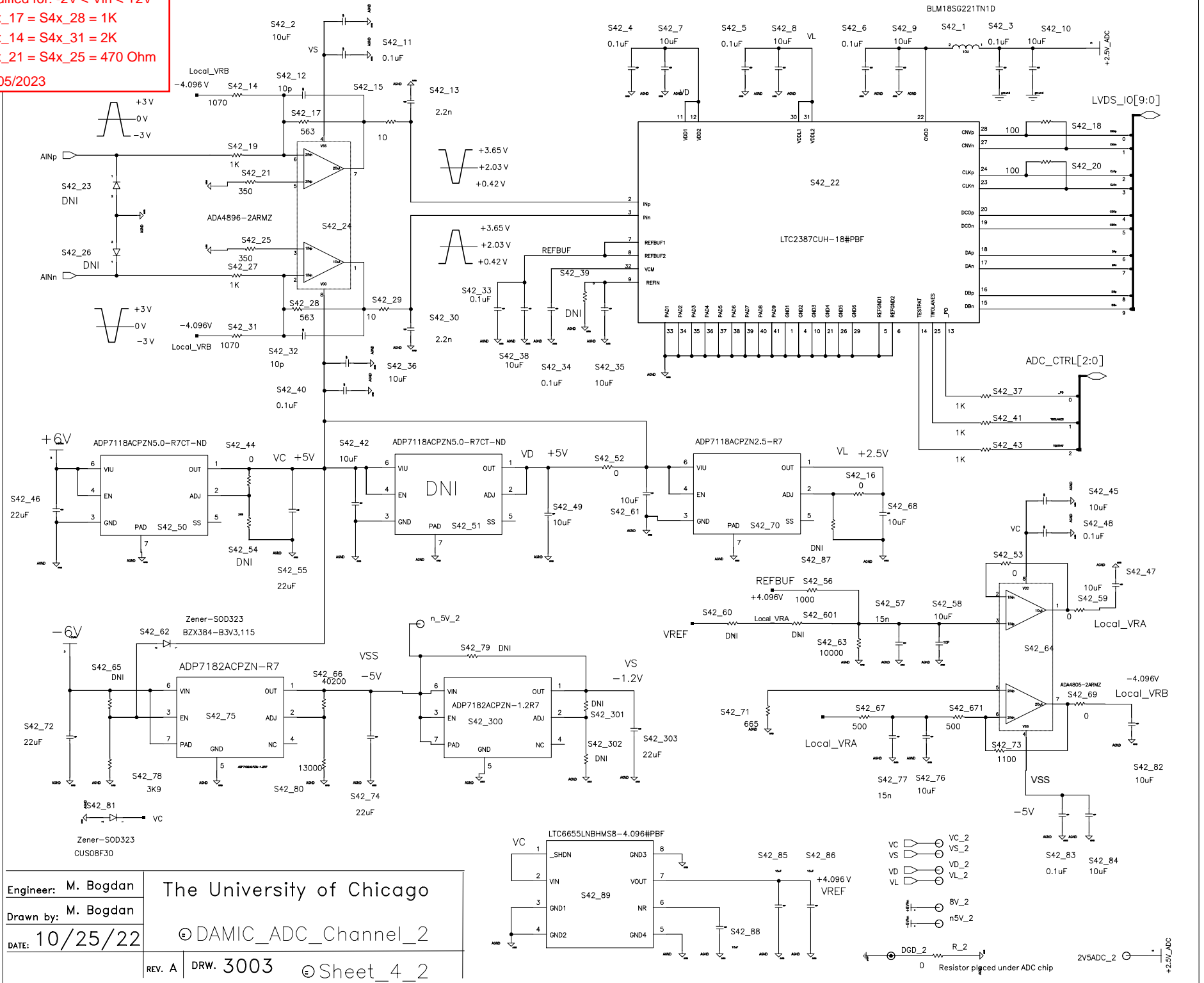

Engineer: M. Bogdan	The University of Chicago
Drawn by: M. Bogdan	
DATE: 10/25/22	© DAMIC_ADC_Channel_2
REV. A	DRW. 3003 © Sheet_4_2